

Power-Generating Modules compliance verification

**Power-Generating Modules type B, C and D
according to NC RfG and Netcode elektriciteit**

Version 2.0

Valid from 1 April 2024

**Netbeheer
Nederland**

Release notes

Version 0.1

Valid from 27 April 2019.

First concept.

New in Version 1.1

Valid from 1 December 2019.

Comments from stakeholders processed

New in Version 1.2

Valid from 21 July 2020

Paragraph 3.2 RfG Operational Notification Procedure

- Operational notification procedure for PGM Type A
- Type B – D main documents
- Operational notification procedure for PGM Type B, C
- Operational notification procedure for type D generators

Paragraph 3.5 Type B – D technical data

Paragraph 3.6 Type B – D test reports

Paragraph 3.7 Type B – D simulation model

Paragraph 4.2.7 Frequency range and Voltage range

- Reference to Netcode elektriciteit article 3.15, sub 9-11.

Paragraph 4.2.8 Reactive power capability

- PPM: Reference to Netcode elektriciteit article 3.19, 3.26, 3.30 on U-Q/Pmax and P-Q/Pmax profiles.

Paragraph 4.2.14: FRT

- Correction to k-factor in PPM test

Paragraph 4.2.18: Fast fault current injection

- PPM: Reference to Netcode elektriciteit article 3.19
- Reference to FGW TG3-2018 Rv. 25 in PPM test

New in Version 1.3.1

Valid from 10 November 2021

Paragraphs 3.2, 4.2.1, 4.2.14, 4.2.16 and 4.2.18

- Exemption for simulations for a PPM type B in the case that the generating units are type tested on the relevant requirements

Paragraph 3.3

- Prototypes

Paragraphs 4.2.1, 4.2.2 and 4.2.3

- Description of the relation between frequency, droop and active power change

Paragraph 4.2.8

- Exemption for reactive power capability site test for a PPM type B in the case that the generating units are type tested on this requirement;
- Reactive Power Capability simulations for PPM and OPPM
- Reactive Power Capability requirements for SPGM

Paragraph 4.2.18: Fast fault current injection

- PPM test: k-factor reference to FGW TG3-2018 Rv. 25; PPM simulation: k-factor in consultation with RSO

Paragraph 4.2.18

- Fast Fault Current Injection simulations

New in Version 1.4

Valid from 8 November 2022

Paragraph 3.8

- The table with details about the type of PPM models and reports that need to be delivered for each model
- Validation reports

Paragraph 3.2, 3.8, 4.1, 4.2.20

- Technical details related to the power quality requirements
- Text corrections related to the inapplicability of power quality requirements to type B and C PGMs.

Paragraph 4.2.18

- Simulation of voltage dip in Fast fault current injection simulations

Paragraph 4.2.15

- Description of the ways of disconnecting PGMs from the network in the Reconnection after disconnection Test.

Paragraph 4.2.5 and 4.2.6

- Few wording corrections

New in Version 2.0

Valid from 1 April 2024

General

- Text from Netcode updated to latest version of Netcode (1-2-2024)

Paragraph 2.2 Definitions

- Definition of Connection capacity added
- Definition of tolerance added. In several paragraphs included tolerance requirements.

Paragraph 3.2 RFG Operational Notification Procedure

- Added that a preliminary PGMD has to be submitted at least 3 month before completion and final test, excluding test results and the final PGMD to be submitted within 6 months after the preliminary PGMD

Paragraph 3.8 Type B – D simulation model

- Annexes added with requirements for generator unit and controller RMS and EMT simulation models

Paragraph 4.1 RFG Compliance

- Simplification for tests on small Type D plants: when Pmax of the PGM is below 10 MW and Pmax is below 50% of the Connection capacity, the tests at site can be limited to those site tests required for Type B PGM
- Added on site testing mandatory for PGM of 5 MW and above
- Added simplification for testing small sized PGMD (<10 MW and <50% connection capacity)
- Deletion LFSM-O simulations for Type B when unit certificates and park controller certificates are available

Paragraphs 4.2.1, 4.2.2, 4.2.3, 4.2.4 Requirements LFSM-O/U, FSM, Frequency restoration

- Frequency sensitivity mode (frequency control) droop for testing and simulation changed from 4% to 5%, the default setting according Netcode
- Included to curtail power during test to prevent power changes because of changing wind and solar conditions during test
- Included default operation points for SPGM and PPM for testing
- Added test points for frequency restoration test

Paragraph 4.2.8 Reactive power capability

- Reactive power capability test duration for Type B ≥ 5 MW reduced to 10 minutes instead of 60 or 30 minutes for Type C, D
- Deleted maximum power factor range because maximum reactive power range is the requirement
- Added requirements for SPGM simulations

Paragraph 4.2.9 Active power controllability

- PPM in reactive power control mode instead of voltage control mode during test

Paragraph 4.2.12 Power factor control mode

- Included to curtail power during test to prevent power changes because of changing wind and solar conditions during test
- Redefined step size power factor changes

Paragraph 4.2.14 FRT

- Updated Netcode requirements for FRT voltage profile (Voltage-time)

Paragraph 4.2.15 Reconnection after disconnection

- Updated test requirements with requirements from Netcode, including options for automatic or manual reconnection
- Added that facility owner shall inform RSO on reconnection procedure
- Added that separate connections to LV grid shall also be disconnected for the test

Paragraph 4.2.18 Fast fault current injection

- Updated Netcode requirements for FRT voltage profile (Voltage-time) and related fast fault current injection duration

Annexes: RMS and EMT models

- Added TenneT annexes with requirements for RMS and EMT simulation models

Contents

Release notes	2
1. Scope	6
2. Definitions	6
2.1 Abbreviations	6
2.2 Definitions	7
3. Operational Notification Procedure for New Power Generating Modules	9
3.1 RfG type definition	9
3.2 RfG Operational Notification Procedure	11
3.3 Prototype generating units in PPM	20
3.4 Type A documents	21
3.5 Type B – D main documents	22
3.6 Type B – D technical data	22
3.7 Type B – D test reports	23
3.8 Type B – D simulation model	24
4. Grid connection of generators (RfG)	26
4.1 RfG compliance	26
4.2 RfG compliance testing and simulation for PGM	31
4.2.1 Requirement: LFSM-O	31
4.2.2 Requirement: LFSM-U	37
4.2.3 FSM	44
4.2.4 Frequency restoration	51
4.2.5 Black start capability (if applicable)	54
4.2.6 Tripping to houseload	58
4.2.7 Frequency range and Voltage range	60
4.2.8 Reactive power capability	66
4.2.9 Active power controllability	84
4.2.10 Voltage control mode (sub-mode 1 and sub-mode 2)	86
4.2.11 Reactive power control mode	93
4.2.12 Power factor control mode	96
4.2.13 Island operation (if applicable)	100
4.2.14 FRT (profiles different B/C and D)	102
4.2.15 Reconnecting after disconnection	112
4.2.16 Post fault active power recovery	114
4.2.17 Power Oscillation Damping Control (POD) (if applicable)	117
4.2.18 Fast fault current injection	121
4.2.19 Synthetic inertia (If applicable)	129
4.2.20 Power Quality	131
4.2.21 Insulation coordination	143

1. Scope

It is a requirement of each of the Connection Network Codes (CNCs) that equipment, affected by the connection code and connected to the system is compliant with the technical requirements forming part of the CNCs at the time that such equipment is first connected and that it then continues to be compliant throughout its life. This document describes the Compliance Verification Procedure for connection of new Power-Generating Modules (EU regulation 2016/631: NC RfG). The NC RfG has been implemented in the Netcode elektriciteit, available in the Dutch language only. All references in the English language are unofficial translations of the official Dutch texts in order to be consistent with this document.

2. Definitions

2.1 Abbreviations

The following list of abbreviations gives an overview of the most common abbreviations in this document. For further explanation of terminology used, we refer to the relevant regulations and codes.

Abbreviation	Description
ATO	Aansluit- en Transportovereenkomst – Connection Agreement
CNC	Connection Network Code
DSO	Distribution System Operator
CDSO	Closed Distribution System Operator
DR	Demand Response
EqC	Equipment Certificate
EON	Energisation Operational Notification
ION	Interim Operational Notification
FON	Final Operational Notification
LON	Limited Operational Notification
NC RfG	Network Code for Requirements for Grid Connection Applicable to all Generators
OPPM	Offshore Power Park Module
PGFO	Power-Generation Facility Owner
PGM	Power-Generating Module
PGMD	Power-Generating Module Document
GU	Generating Unit
PPM	Power Park Module
RSO	Relevant System Operator
SPGM	Synchronous Power Generating Module
TSO	Transmission System Operator

2.2 Definitions

The following list of definitions gives an overview of the most common terms in this document. For further explanation of terminology used, we refer to the relevant regulations and codes. Definitions from European Network Codes:

- **Connection agreement:** a contract between the relevant system operator and either the power-generating facility owner, demand facility owner, distribution system operator or HVDC system owner, which includes the relevant site and specific technical requirements for the power-generating facility, demand facility, distribution system, distribution system connection or HVDC system
- **Connection Point:** the interface at which the Power-Generating Module, demand facility, distribution system or HVDC system is connected to a transmission system, offshore network, distribution system, including closed distribution systems, or HVDC system, as identified in the connection agreement
- **Connection Capacity: the transmission capacity of the connection as stated in the Connection Agreement**
- **Energisation Operational Notification (EON):** a notification issued by the relevant system operator to a power-generating facility owner, demand facility owner, distribution system operator or HVDC system owner prior to energisation of its internal network
- **Interim Operational Notification (ION):** a notification issued by the relevant system operator to a power-generating facility owner, demand facility owner, distribution system operator or HVDC system owner which allows them to operate respectively a power-generating module, demand facility, distribution system or HVDC system by using the grid connection for a limited period of time and to initiate compliance tests to ensure compliance with the relevant specifications and requirements
- **Final Operational Notification (FON):** a notification issued by the relevant system operator to a power-generating facility owner, demand facility owner, distribution system operator or HVDC system owner who complies with the relevant specifications and requirements, allowing them to operate respectively a power-generating module, demand facility, distribution system or HVDC system by using the grid connection
- **Limited Operational Notification (LON):** a notification issued by the relevant system operator to a power-generating facility owner, demand facility owner, distribution system operator or HVDC system owner who had previously attained FON status but is temporarily subject to either a significant modification or loss of capability resulting in non-compliance with the relevant specifications and requirements
- **Installation document:** means a simple structured document containing information about a type A Power-Generating Module or a demand unit, with demand response connected below 1000V, and confirming its compliance with the specified requirements
- **Main Generating Plant:** one or more of the principal items of equipment required to convert the primary source of energy into electricity;
- **Maximum Capacity (P_{max}):** the maximum continuous active power which a Power-Generating Module can produce, less any demand associated solely with facilitating the operation of that Power-Generating Module and not fed into the network as specified in the connection agreement or as agreed between the relevant system operator and the Power-Generating Facility Owner
- **Minimum Regulating Level:** the minimum active power, as specified in the connection agreement or as agreed between the relevant system operator and the Power-Generating Facility Owner, down to which the power-generating module can control active power

- **Power-Generating Module (PGM):** either a synchronous Power-Generating Module or a Power Park Module
- **Synchronous Power-Generating Module (SPGM):** an indivisible set of installations which can generate electrical energy such that the frequency of the generated voltage, the generator speed and the frequency of network voltage are in a constant ratio and thus in synchronism
- **Power Park Module (PPM):** a unit or ensemble of units generating electricity, which is either non-synchronously connected to the network or connected through power electronics, and that also has a single Connection Point to a transmission system, distribution system including closed distribution system or HVDC system
- **Offshore Power Park Module (OPPM):** a Power Park Module located offshore with an offshore Connection Point
- **Power-Generating Facility:** a facility that converts primary energy into electrical energy and which consists of one or more Power-Generating Modules connected to a network at one or more Connection Points
- **Power-Generating Facility Owner (PGFO):** a natural or legal entity owning a Power-Generating Facility
- **Power-Generating Module Document (PGMD):** a document provided by the Power-Generating Facility Owner to the relevant system operator for a type B or C Power-Generating Module which confirms that the power-generating module's compliance with the technical criteria set out in this Regulation has been demonstrated and provides the necessary data and statements, including a statement of compliance
- **Relevant TSO:** the TSO in whose control area a Power-Generating Module, a demand facility, a distribution system or a HVDC system is or will be connected to the network at any voltage level; in The Netherlands the relevant TSO is TenneT
- **Relevant System Operator (RSO):** the transmission system operator or distribution system operator to whose system a Power-Generating Module, demand facility, distribution system or HVDC system is or will be connected
- **Statement of compliance:** means a document provided by the Power-Generating Facility Owner, demand facility owner, distribution system operator or HVDC system owner to the system operator stating the current status of compliance with the relevant specifications and requirements;

Other definitions and clarifications used in this document:

- **Aansluitpunt:** equal to Connection Point RfG)
- **Connected party:** either a power-generating facility owner, demand facility owner, distribution system operator or HVDC system owner
- **Generating Unit (GU):** an individual unit of a Power Park Module converting energy into electricity, e.g. a single wind turbine or one or more inverters with solar panels
- **Dead time (Td):** the time from the frequency change event until the beginning of the response
- **Step response time (Tsr):** the time from the change event until the instant the response reaches the tolerance range for the first time
- **Settling time (Ts):** the time from the change event until the instant from where on the corresponding response remains within the tolerance band of the set value
- **Tolerance:** permitted deviation between the declared value of the quantity and the measured value. (IEC IEC reference 411-36-19)
- **Voltage control mode deadband:** an interval used intentionally to make the voltage control unresponsive

3. Operational Notification Procedure for New Power Generating Modules

3.1 RfG type definition

The EU regulation 2016/631 (RfG) defines four types of generators A, B, C and D in Article 5 “Determination of significance”, as described in chapter 3. The fundamental rationale for creating the type definition is that the size of a Power-Generating Module impacts the stability of the grid – the larger one single PGM the more impact. The impact of a large amount of small PGM’s (e.g. on frequency stability) is reflected in the requirements. All requirements in the said regulation are cumulative, with some exemptions, sorted into the four types. The compliance testing and simulation of Power-Generating Modules follow the same basic principle.

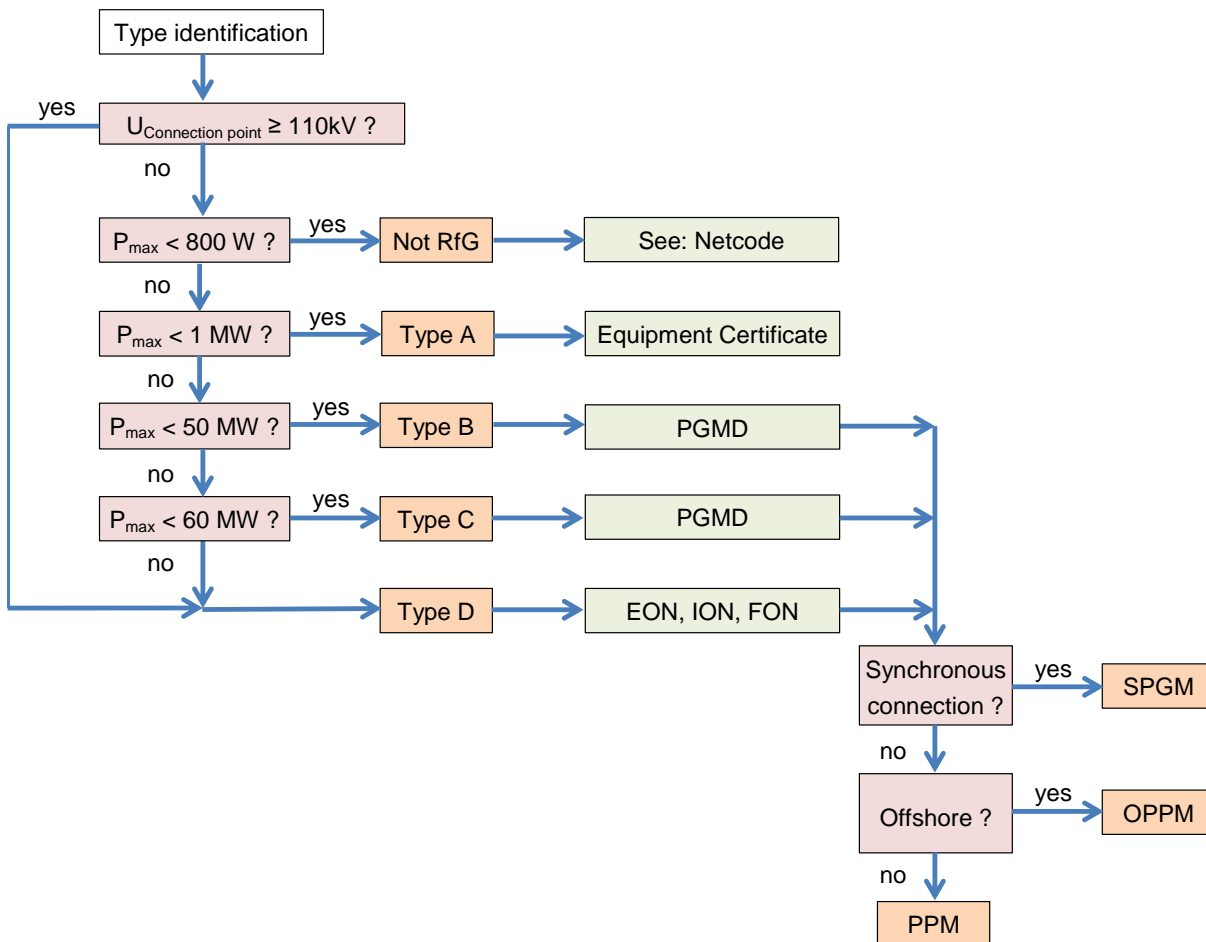

Figure 3.1 RfG Type identification

The following definitions are taken from RfG article 2:

- SPGM: Synchronous Power-Generating Module means an indivisible set of installations which can generate electrical energy such that the frequency of the generated voltage, the generator speed and the frequency of network voltage are in a constant ratio and thus in synchronism

- PPM: Power Park Module means a unit or ensemble of units generating electricity, which is either non-synchronously connected to the network or connected through power electronics, and that also has a single Connection Point to a transmission system, distribution system including closed distribution system or HVDC system
- OPPM: Offshore Power Park module means an AC connected Power Park Module located offshore with an offshore Connection Point.

A (power generating) unit is a single generating installation converting energy into electricity. A generating unit in an SPGM may be a gas turbine installation. A generating unit in a PPM may be a single wind turbine, a single inverter with connected photovoltaic cells (PV).

To these definitions, a conventional power plant is treated as an SPGM. A wind power plant and a PV solar power plant are treated as a PPM. Also a wind power plant with doubly fed induction generators (DFIG) is a PPM, since the generator speed and the frequency of network voltage are not in a constant ratio (see: RfG, article 2, definition 9). An offshore AC connected offshore wind power plant is treated as an OPPM. However, an onshore AC connected offshore wind power plant is treated as a PPM. An offshore power plant that is connected through an HVDC-system is treated as a DC connected Power Park Module in NC HVDC.

Referring to the definitions (paragraph 2.2) the logical hierarchy is:

- Facility
 - Power-Generating Module (may be Synchronous Power-Generating Module or PPM)
 - Generating Unit (e.g. Gas turbine, Wind Turbine, PV inverter)

From RfG Whereas (9): The significance of power-generating modules should be based on their size and their effect on the overall system.

- Synchronous machines should be classed on the machine size and include all the components of a generating facility that normally run indivisibly, such as separate alternators driven by the separate gas and steam turbines of a single combined-cycle gas turbine installation. For a facility including several such combined-cycle gas turbine installations, each should be assessed on its size, and not on the whole capacity of the facility.
- Non- synchronously connected generating units, where they are collected together to form an economic unit and where they have a single connection point should be assessed on their aggregated capacity.

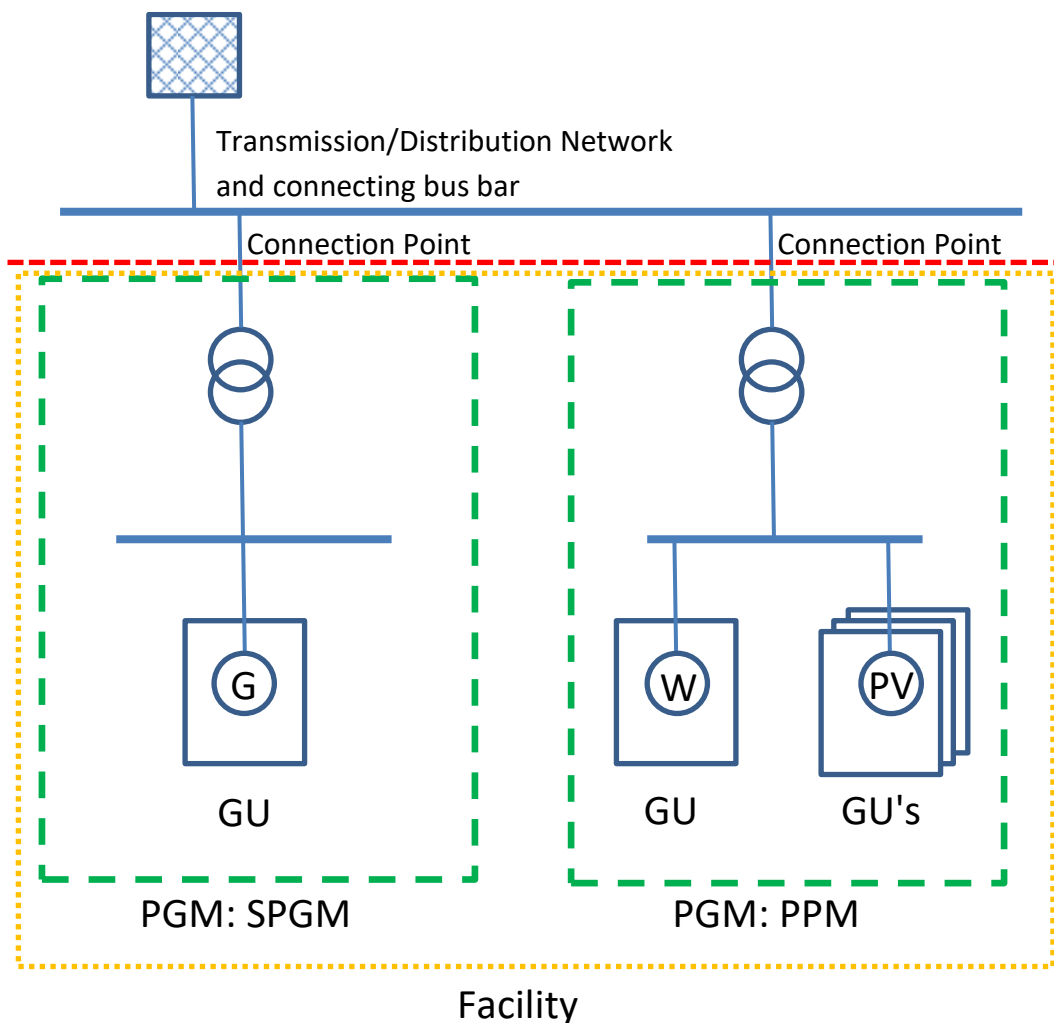

Figure 3.2 Facility, PGM, SPGM and PPM

3.2 RfG Operational Notification Procedure

This paragraph sets out the requirements for new generators to demonstrate their compliance with the detailed technical specifications for generators, as part of their connection process. The operational notification process sets out the steps through which demonstration of these requirements can be achieved including steady state and dynamic performance.

The operational notification process depends on the size and the connection voltage of the Power-Generating Module and thus on their impact on the system. Synchronous machines should be classed on the machine size and include all the components of a generating facility that normally run indivisibly, such as separate alternators driven by the separate gas and steam turbines of a single combined-cycle gas turbine installation. For a facility including several such combined-cycle gas turbine installations, each should be assessed on its size, and not on the whole capacity of the facility. Non- synchronously connected Generating Units, where they are collected together to form an economic unit and where they have a single Connection Point (e.g. wind turbine parks and solar PV parks) should be assessed on their aggregated capacity.

The on-shore Power-Generating Modules are subdivided into four types A to D. The operational notification procedure is specified for each type A-D of Power-Generating Module and is broadly as follows:

- Type A Power-Generating Modules have a Connection Point below 110 kV and Maximum Capacity between 0.8 kW and 1 MW (not inclusive);
- Type B Power-Generating Modules have a Connection Point below 110 kV and Maximum Capacity between 1 MW and 50 MW (not inclusive);
- Type C Power-Generating Modules have a Connection Point below 110 kV and Maximum Capacity between 50 MW and 60 MW (not inclusive);
- Type D Power-Generating Modules have a Connection Point at 110 kV or above.
A Power-Generating Modules is also of type D if its Connection Point is below 110 kV and its Maximum Capacity is at or above 60 MW.

For type A an installation document shall include the equipment certificates and other additional information such as source (e.g. PV) and kW rating.

Types B, C and D need significant site-specific supporting compliance evidence. For types B and C a Power Generating Module Document (PGMD) is to be provided by the Power-Generating Facility Owner (PGFO) to the Relevant System Operator (RSO) for each Power-Generating Module, including a statement of compliance.

For type D generators the process is more extensive, due to their scale and potential impact on the system, the extent of the services and technical capabilities that they should be able to provide or demonstrate, and their capability to engage in more detailed testing. Proof of evidence can be provided e.g. by a project certificate containing simulations with validated electrical simulation models. These project certificates should be based on type certificates or/and equipment certificates.

Operational notification procedure for PGM Type A

For each Power-Generating Module the Power Generating Facility Owner (PGFO) provides an installation document to the RSO, see paragraph 3.4. Any equipment forming part of the installation is to be covered by Equipment Certificates (EqCs) issued by an authorised certifier.

Operational notification procedure for PGM Type B, C

A Power Generating Module Document (PGMD) is to be provided by the Power Generating Facility Owner (PGFO) to the Relevant System Operator (RSO) for each Power-Generating Module, including a statement of compliance. The PGMD contains the information that demonstrates compliance with the technical criteria. It shall include test reports and simulation studies reports. The test reports are required by RfG chapters 2-4 of title IV and they include use of actual measured values during testing. The simulation studies reports are required by RfG chapters 5-7 of title IV and they demonstrate steady state and dynamic performance.

The PGFO of a PGM type B can, instead of conducting tests, prove compliance with the relevant requirements by means of calculations, based on the by certificates or test reports proven properties of the applied components and/or generating units. If a PGM (park) controller is applied, the proper functioning of the park controller in combination with the applied generating units shall be demonstrated.

In the case that a prototype generating unit is used in a PPM, see paragraph 3.3.

Procedure

The PGMD is published on the website of Netbeheer Nederland:

<https://www.netbeheernederland.nl/dossiers/regulering-20/documenten>.

For each Power-Generating Module within the Power-Generating Facility, the Power Generating Facility Owner (PGFO) provides a separate independent PGMD to the relevant system operator (RSO), containing the following documents and reports (RfG article 32):

- Evidence of an agreement on the protection and control settings relevant to the Connection Point;
- Itemised statement of compliance;
- Detailed technical data of the PGM as specified by chapter 13 of the Netcode elektriciteit;
- Equipment certificates;
- For Type C Power-Generating Modules, simulation models (see paragraph 3.8);
- Compliance test reports demonstrating steady-state and dynamic performance;
- Studies demonstrating steady-state and dynamic performance.

Additional information:

- Signed connection agreement (ATO);
- Protection and settings document (co-ordination with RSO substation protection, see also Netcode elektriciteit article 2.37);
- Signal exchange list (agreed between RSO and PGFO);
- Report providing the power quality compliance (according to IEC 61400-21-1:2019);
- For type C: Conformity that power quality measurements can and will be performed during the commissioning;
- Actual planning information (all relevant planning of notification process information shall be delivered by the PGFO);
- An overall testing and commissioning plan.

Planning

- The PGFO requests connection for a PGM type B or C; this can be on a new connection point or on an existing connection point;
- The RSO checks the network capacity;
- The RSO sends links to PGMD and Power-Generating Modules compliance verification document to the PGFO;
- The RSO informs the PGFO of the relevant network data; the PGFO needs this data to prepare the tests and execute the simulations;
- The PGFO hands over the detailed technical data, as specified in the PGMD;
- The PGFO hands over a protection and settings document, as specified in the PGMD, a signal exchange list and an overall testing and commissioning plan;
- The PGFO hands over the available Equipment Certificates as soon as possible;
- The PGFO hands over the results of the simulation studies as soon as possible;
- The RSO issues a notification to energise the substation and to connect the power-generating facility for the purpose of construction and testing activities;
- The PGFO hands over the actual planning information and the overall testing and commissioning plan;
- Commissioning of the Generating Units of the PGM and the possible plant controller;
- Execution of required tests, as specified in chapter 4;
- Within a period of two months after energising of the substation and at least three months for PGM <5 MW and at least 6 months for PGM ≥ 5 MW before the desired completion date of the PGM, the PGFO shall submit a preliminary PGMD, accompanied with the preliminary statement of compliance, including reports of test procedures and simulation results;
- Within a period of 6 months after the preliminary PGMD, the PGFO shall submit the final PGMD, accompanied with the final statement of compliance, including reports with results of tests and simulation results
- In case of a wind or solar powered PPM and in case of a lack of primary solar or wind power due to seasonal influences and with the consequence that the required output power cannot

be achieved, the tests shall be postponed until sufficient primary power is available; in this case, the PGFO shall submit a preliminary version of the PGMD at least three months before the desired commissioning of the PPM and the final version of the PGMD no later than three months after reaching the full installed PPM capacity;

- Within a maximum of two months after receiving the statement of compliance of the Power Generating Facility Owner (PGFO), the RSO will respond;
- If the assessment of the statement of compliance is positive, the RSO will accept the PGMD;
- On acceptance of the complete and adequate PGMD, the RSO issues a final operational notification to the power-generating facility owner
- If the RSO does not accept the PGMD, he will send the PGFO the reason for refusal, after which the PGFO will have the option to submit a new version of the PGMD within two months.

Operational notification procedure for type D generators

For type D the process is more extensive due to their scale and potential impact on the system, the extent of the services and technical capabilities that they should be able to provide or demonstrate, and their capability to engage in more detailed testing. The tests shall be carried out on the complete PGM describing its behaviour at the Connection Point, supplemented with type tests on single Generating Units if applicable or components. If a test cannot be carried out at the Connection Point, e.g., if the function does not exist at PGM control level, the on-site test shall be carried out for a representative sample of each GU type to be installed in the PGM. Alternatively, a single Generating Unit shall be tested and the concerning parameters of all other individual units shall be checked.

Figure 3.3 illustrates the connection and commissioning process for a type D PGM. The steps are explained in the following paragraphs. Part of the process is the execution of tests and simulations. According to RfG Article 42(4) the relevant system operator may participate in the compliance testing.

Instead of carrying out the relevant tests or simulations, Power-Generating Facility Owners may rely upon equipment certificates issued by an authorised certifier as part of evidence to demonstrate compliance with the relevant requirements. In such a case, the equipment certificates shall be provided to the relevant system operator, including the Non-Disclosure Agreement (NDA) if needed.

Network connection examination

In the case of grid connection of a PGM, the PGFO and the RSO must exchange data in advance. The PGFO specifies the grid connection planning to the Connection Point determined in the course of the rough planning and informs the RSO of the relevant data of the PGM. The RSO needs this "best available" data to include it in the base network model in order to execute preliminary simulations. Thereupon, the RSO informs the PGFO of the relevant network data. The PGFO needs this data to prepare the tests and simulations.

NC RfG Article 33

- *Energisation operational notification (EON)*
An EON entitles the facility owner to energise their equipment using their connection but not to generate and is subject to the agreement with the RSO of protection and control settings.
- *Interim operational notification (ION)*
An ION entitles the facility owner to operate their Power-Generating Module and to generate for a limited period of time – which is to be specified by the RSO but will be no more than 24 months. Issue of an ION is subject to completion of the data and study review as specified/requested by the RSO including simulation models and studies demonstrating steady state and dynamic performance and details of the intended compliance tests. Tests may be

substituted by the provision of Equipment Certificates (EqCs). Simulations can be based on validated equipment models provided by the EqCs. See RfG Article 35.

- *Final operational notification (FON)*
A FON signifies the completion of the operational notification process and allows the Power-Generating Facility Owner to operate a Power-Generating Module using their grid connection.
- *Limited Operational Notification (LON)*
A type D generator holding a FON must inform the RSO with whom they hold a connection agreement in the case that their equipment is affected by a temporary loss of capability, is subject to significant modification affecting performance, or is affected by equipment failure affecting performance, in each case where this is expected to last for more than 3 months.

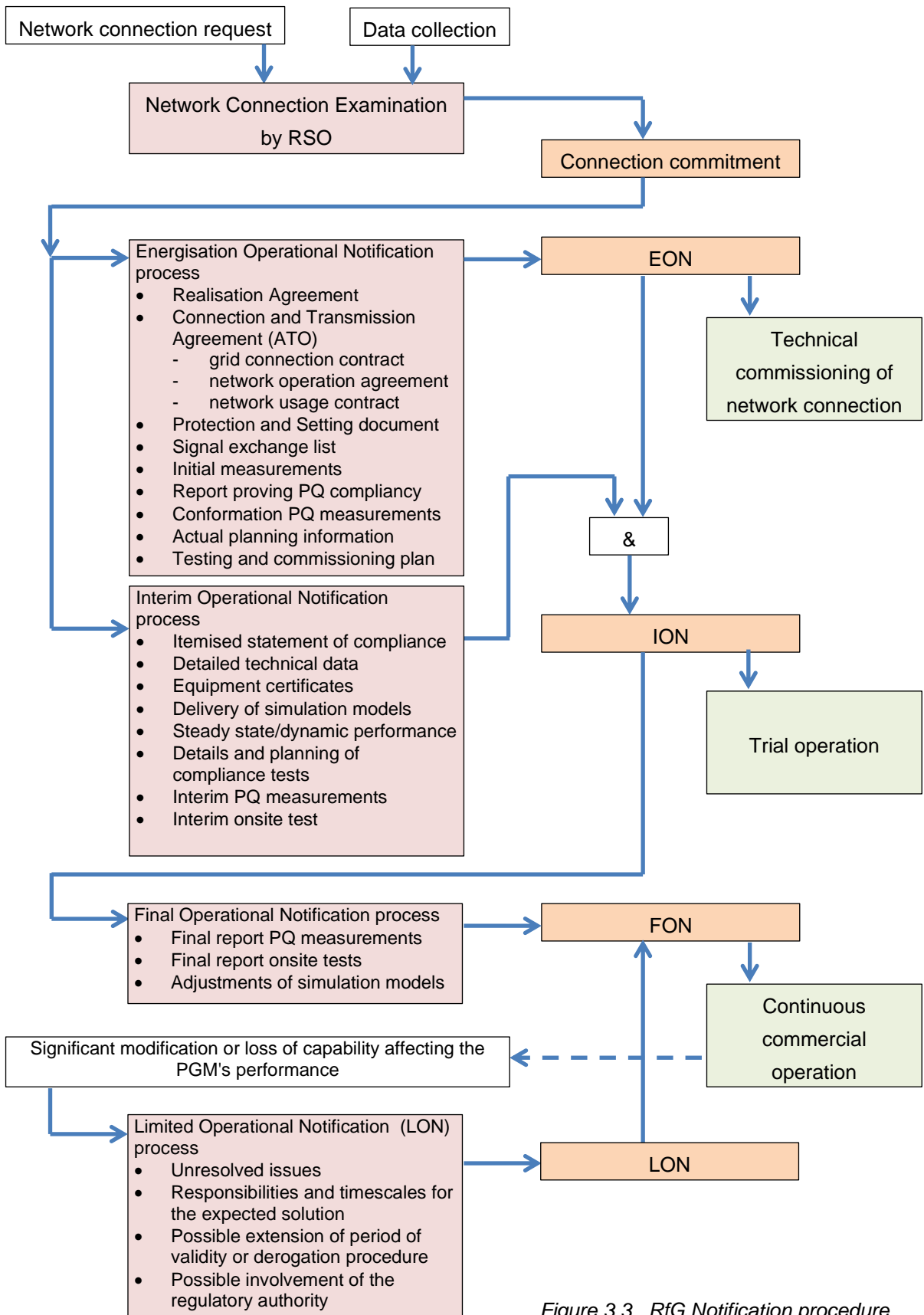

Figure 3.3 RfG Notification procedure

Energisation operational notification (EON)

According to RfG Article 34 an EON entitles the facility owner to energise their equipment using their connection but not to generate [RfG 35 (ION) entitles to generate power] and is subject to the agreement with the RSO of protection and control settings.

Procedure

The Power Generating Facility Owner (PGFO) shall submit a Statement of Compliance to the RSO for issuing an EON. This Statement of Compliance refers to the following documents and reports, all approved by the RSO:

- Realisation Agreement;
- Signed Connection Agreement (ATO: Aansluit- en transportovereenkomst):
 - grid connection contract;
 - network operation agreement;
 - network usage contract;
- Protection and settings document;
- Signal exchange list;
- Initial measurements (power quality)(measurements to be performed after EON is granted and a measuring device shall be in operation one week before energisation of a connection);
- Report providing the power quality compliance;
- Confirmation that power quality measurements can and will be performed during the commissioning;
- Actual planning information;
- Overall testing and commissioning plan, including:
 - Planning of personnel;
 - Contact details of responsible commissioning manager and authorised personnel;
 - Planning of active- and reactive power exchanged till first Generating Unit.

Planning

- At least 16 months before the date of granting the EON, the PGFO requests the necessary information for the harmonic analysis, after which the RSO makes the required information available to the PGFO as quickly as possible;
- A period of minimum 10 months before the date of granting the EON shall be scheduled for review, discussion and approval by the RSO of the report regarding the power quality compliancy;
- Within a maximum of four weeks after receiving the Statement of Compliance of the Power Generating Facility Owner (PGFO), the RSO will respond. If the assessment of the Statement of Compliance is positive an EON will be granted by the RSO;
- The PGFO shall have an EON at least one month before the energization of the connection.

Interim operational notification (ION)

According to RfG Article 35 an ION entitles the facility owner to operate their Power-Generating Module and to generate for a limited period of time – which is to be specified by the RSO but will be no more than 24 months (an extension of this period may be granted if a request for derogation is made to the RSO before the expiry of that period in accordance with the derogation procedure laid down in RfG article 60). Issue of an ION is subject to completion of the data and study review as specified/requested by the RSO including simulation models and studies demonstrating steady state and dynamic performance as required by RfG chapters 5-7 of title IV, and details of the intended compliance tests that are to be undertaken to fulfil RfG chapters 2-4 of title IV. After receiving the ION the compliance tests can be executed. Tests may to some extent be substituted by the provision of EqCs. Simulations can be based on validated equipment models provided by the EqCs.

Procedure

The Power Generating Facility Owner (PGFO) shall submit a statement of compliance to the RSO for issuing an ION. This statement of compliance refers to the following documents and report, all approved by the RSO:

- An EON;
- Itemised Statement of Compliance;
- Detailed technical data on the Generating Units and the Power-Generating Module;
- Equipment certificates in respect of Power-Generating Modules, where they are relied upon as part of the evidence of compliance;
- Simulation models, as required by the RSO;
- Simulation studies demonstrating the expected steady-state and dynamic performance as required by RfG Chapter 5, 6 or 7 of Title IV;
- Details and planning of compliance tests in accordance with RfG Chapters 2, 3 and 4 of Title IV and approved by the RSO;
- Confirmed parameter settings of active power control and voltage control as stated in the connection agreement;
- Interim power quality measurements (measurements to be performed after ION is granted and before interim operation starts);
- Interim voltage test procedure.

Planning

- Within a maximum of four weeks after receiving the statement of compliance of the Power Generating Facility Owner (PGFO), the RSO will respond. If the assessment of compliance is positive an ION will be granted by the RSO;
- The PGFO shall have an ION at least one month before taking the first Generating Unit in operation;
- After receiving the ION the compliance tests can be executed.

Final operational notification (FON)

A FON signifies the completion of the operational notification process and allows the Power-Generating Facility Owner to operate a Power-Generating Module using their grid connection. To progress a FON the facility owner has to have an ION. Completion of the FON is subject to completion of any outstanding requirements set out in the ION and must include submission, by the facility owner, of an itemized statement of compliance and an update of the technical data, studies and models provided as part of the ION but now also validated and using actual values found through testing.

In case of an (O)PPM, the Interim Operational Notification (ION) gives the right to produce with a limited amount of Generating Units simultaneously in operation in such a way that the maximum actual output of the (O)PPM does not exceed 20% of the final maximum capacity of the (O)PPM.

- If the Power Generating Facility Owner (PGFO) has completed all the interim tests and measurements with the first Generation Units to reasonable satisfaction of the RSO, the mentioned power output limitation is cancelled.
- Following successful completion of this test each additional Generating Unit should be included in the voltage control scheme as soon as is technically possible (unless the RSO agrees otherwise).
- The interim tests can be skipped in case the expected building-time between 20% of full capacity and full capacity is less than one week and if there is enough primary sun power or wind power expected to run the full FON-tests. In that case the FON-tests will be applied only. In case the mentioned building-time appeared to be more than one week the interim

tests can still be ordered by the relevant RSO.

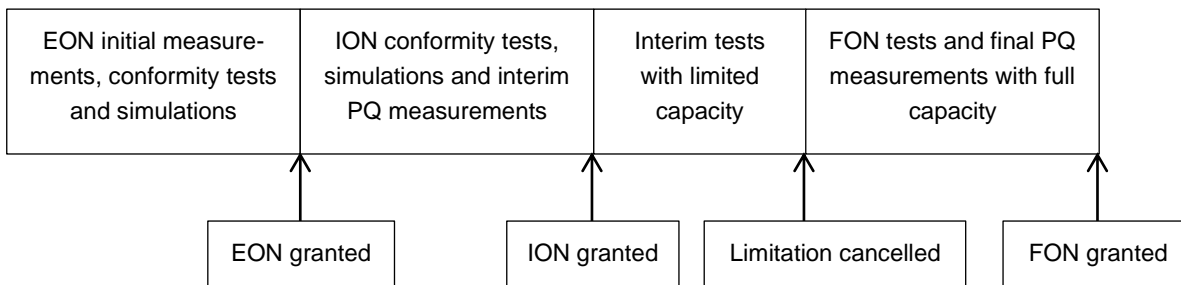

In general, the PGFO must have a FON no later than four months after reaching the full installed PGM capacity. FON-tests in particular require a minimum output power of 60 % of the maximum capacity. In case of a wind or solar powered (O)PPM and in case of a lack of primary solar or wind power due to seasonal influences and with the consequence that the required output power cannot be achieved, the FON-tests shall be postponed until sufficient primary power is available. In this case, the (O)PPM must have a FON no later than eight months after reaching the full installed (O)PPM capacity. During this delay, the (O)PPM is allowed to operate with a valid ION.

Part of the FON should be an agreement between RSO and facility owner, how compliance will be monitored over the life time of the generator, taking into account possible changes in controller software, hardware and also changes in the Connection Point characteristics like short circuit power and frequency impedance characteristics This agreement will be initiated by the RSO and can be assured by a continuous compliance monitoring.

Procedure:

The Power Generating Facility Owner (PGFO) shall submit a statement of compliance to the RSO for issuing a FON. This statement of compliance refers to the following documents and reports:

- An ION;
- Final report on power quality measurements approved by the RSO;
- Final report full on-site tests approved by the RSO;
- Simulation models, validated against test results (as built);
- Motivation and/or re-simulations approved by the RSO, as result of as built values.

Planning

- Within a maximum of four weeks after receiving the statement of compliance of the Power Generating Facility Owner (PGFO), the RSO will respond. If the assessment of compliance is positive a FON will be granted by the RSO;
- The PGFO shall ensure that he has a FON no later than four months after reaching full installed PGM capacity;
- In case of an (O)PPM, the PGFO may postpone the FON date by a maximum of four extra months if the weather conditions do not allow the required output power for the FON tests.

Limited Operational Notification (LON)

A type D generator holding a FON must inform the RSO with whom they hold a connection agreement immediately in the case that their equipment is affected by a temporary loss of capability, is subject to significant modification affecting performance, or is affected by equipment failure affecting performance. A LON shall be granted in each case where this is expected to last for more than 3 months (RfG Article 37(2)).

Issue of a LON by the RSO should be subject to identification of the means and timescales by which the non-compliance will be resolved and can last for a maximum of 12 months without requiring a further derogation. A further expansion of the period of validity of the LON may be granted upon a request for a derogation made by the RSO before the expiry of that period, in accordance with the derogation described in RfG Title V.

Consequences in case a notification cannot be granted in time

In order to maintain system stability the RSO is entitled to:

- Refuse energizing of the connection in case an EON cannot be granted a minimum of one month before energization of the connection;
- Refuse power production in case an ION cannot be granted a minimum of one month before connection of the first Generating Unit;
- Order to limit power production to 20% of the Maximum Capacity of the (O)PPM in case all the interim tests and measurements, mentioned in the ION paragraph have not been completed to reasonable satisfaction of the RSO;
- Order to stop power production in case a FON cannot be granted a minimum of four months after reaching full commissioned Power-Generating Module capacity and the ION has been expired.

3.3 Prototype generating units in PPM

A prototype generating unit is the first power generating unit of a type (and all power generating units of this type that are taken into service within a time period of two years after the commissioning of the first power generating unit of this type) that undergoes significant technical development or innovation. Significant technical developments and innovations occur when components or software versions are changed in such a way that the electrical behaviour on the grid changes significantly.

Documentation (see paragraph 3.2) is to be provided by the Power Generating Facility Owner (PGFO) to the Relevant System Operator (RSO) for each Power-Generating Module (PGM), including a statement of compliance in order to obtain a final operational notification. The documentation contains the information that demonstrates compliance of the PGM with the technical criteria of the NC RfG and Dutch Netcode elektriciteit. The PGFO may use type test reports approved by an independent body or test report included within a certificate of a unit issued by an authorised certifier to demonstrate compliance of the PGM with the relevant requirements. In that case, the type test reports approved by an independent body or test report included within a certificate of a unit shall be provided to the RSO.

In case of a prototype generating unit, no unit certificates or type test reports will be available on short notice. In that case, the documentation for demonstrating the compliance of a PPM with the technical criteria of the NC RfG and Dutch Netcode elektriciteit can be based on a prototype confirmation, which is based on a manufacturers declaration and approved by an independent certification body. Within a period of two years after taking into service of the first prototype power generating unit in The Netherlands, a prototype confirmation will be sufficient instead of the type test reports approved by an independent body or test report included within a certificate of a unit. The certification body confirms the existence of a significant technical development or innovation on the basis of a manufacturer's declaration. The certification body also verifies and states in the prototype confirmation that the prototype is principally able to comply with the requirements of the NC RfG and Dutch Netcode elektriciteit. Manufacturer and independent certifying body have the responsibility that the documentation is correct. The prototype confirmation also mentions the expected date of the final type test reports. The generating unit prototype confirmation can be used by the PGFO to demonstrate

compliance of the PPM in which the prototype is installed. After approval by the RSO, the PGFO receives a temporary operational notification to start operation.

The documentation of the power generating unit specifications shall contain at least:

- Electrical data (nominal and rated quantities);
- Schematic overview circuit diagram of the power generating unit with all relevant components;
- Operating ranges of the power generating unit:
 - Limits in quasi-static operation;
 - Reactive power adjustment range;
 - FRT limit curve;
- Protection functions with setting ranges:
 - Disconnection protection;
 - Self-protection;
- Active power control:
 - Power/frequency behaviour;
 - Active power gradient;
- Reactive power control;
- Fast fault current injection.

The manufacturer declares that the prototype generating unit has been designed so that it is principally able to comply with the relevant requirements of the NC RfG and Dutch Netcode elektriciteit. If a prototype confirmation is available based on requirements other than the Dutch Netcode elektriciteit, this prototype confirmation will only be accepted as far as those requirements are equal or more stringent than the Dutch Netcode elektriciteit. For those requirements which are less stringent than the requirements in the Dutch Netcode elektriciteit, an additional statement will be required with the prototype confirmation.

Within the period of two years, type test reports approved by an independent body or test report included within a certificate of a unit is required. If after this time period the PGFO is not able to hand over the type test reports approved by an independent body or test report included within a certificate of a unit and the resulting declaration of conformity to the relevant system operator (RSO), the RSO is entitled to require taking out of operation the concerned prototype generating units or to disconnect the PGM from the network. This principle, based on NC RfG article 3, will be included in a temporary operational notification for the PGM, issued by the RSO.

After accepting the complete and adequate documentation for demonstrating the compliance of the PPM, including the type test reports approved by an independent body or test report included within a certificate of a unit, the extracts of the test reports and the resulting declaration of conformity with the NC RfG and Dutch Netcode elektriciteit, the RSO shall issue the final operational notification to the power-generating facility owner.

3.4 Type A documents

According to NC RfG article 30 the operational notification procedure for connection of each new type A power-generating module consists of submitting an installation document. The contents of the installation document are specified by the RSO. The contents are:

- the location at which the connection is made;
- the date of the connection;
- manufacturer and type-identification;

- the Maximum Capacity of the installation in kW;
- the type of primary energy source (e.g. PV, Wind);
- the classification of the Power-Generating Module if it is an emerging technology according to Title VI of the RfG;
- capability for electricity storage;
- reference to equipment certificates issued by an authorised certifier used for equipment that is in the site installation;
- as regards equipment used, for which an equipment certificate has not been received, information shall be provided as directed by the relevant system operator;
- the contact details of the Power-Generating Facility Owner and the installer and their signatures.

The installation document refers to equipment certificates. The Power-Generating Facility Owner may rely upon equipment certificates. The equipment certificates describe the extent to which the relevant requirements are met.

3.5 Type B – D main documents

For PGM type D and, as applicable, for types B and C, the Power Generating Facility Owner (PGFO) shall hand over to the RSO,:

- Results and details of physical tests
- Results and details of simulations
- Technical data
- Statement of compliance
- Actual planning of:
 - Energisation, First Generating Unit (in case of a (O)PPM), 20% of the Maximum Capacity of the (O)PPM, and full capacity
 - In case of type B or C PGM: Delivery of statement of compliance PGMD
 - In case of type D PGM: Delivery of statement of compliance EON, ION and FON
 - Delivery of documents on compliancy tests and simulations
 - Onsite tests

In case of type B or C PGM: From RSO to Power Generating Facility Owner (PGFO)

- Reviews of simulations and test results (PGMD)
- Declaration of acceptance of the PGMD (RfG Article 32(3)).

In case of type D PGM: From the RSO to Power Generating Facility Owner (PGFO)

- Reviews of simulations and test results
- Energization operational notification (EON)
- Interim operational notification (ION)
- Final operational notification (FON).

3.6 Type B – D technical data

According to RfG articles 32(2) and 35(2) the relevant system operator will request that the power-generating facility owner provides all detailed technical data of the Power-Generating Module with relevance to the grid connection as specified by the relevant system operator, as described in chapter 13 of the Netcode elektriciteit.

3.7 Type B – D test reports

Type tests may be performed either by an independent test institute, by the PGFO or by the manufacturer. If the type tests are performed by the PGFO or the manufacturer, they need to be witnessed and approved by an independent test institute.

In case of a type test, a report (hereafter called 'Generating Unit test report') shall cover information from type tests according to FGW TG3-2018 Rv. 25, as well as information on additional tests and information, if required by the RSO. In detail the 'Generating Unit test report' shall include:

- Reactive power capability including PQ and PV diagrams based on measurements;
- Report on fault-ride-through capability according to the requirements including measurements;
- Report on fast fault current injection tests for an (O)PPM Generating Unit;
- Test reports for operation during:
 - Over and under frequency according to RfG article 13(1) and Netcode elektriciteit article 3.13 sub 1;
 - Over and under voltage according to Netcode elektriciteit 3.15, sub 9 (PGM with voltage higher than 1 kV and lower than 110 kV), RfG article 16(2) and Netcode elektriciteit 3.28, sub 1 (PGM type D) and RfG article 25(3) and Netcode elektriciteit article 3.33 sub 1 (OPPM).
- Power quality conformity test measurements:
 - Nederlandse praktijkrichtlijn NPR-IEC/TR 61000-3-6:2008 (en) Electromagnetic compatibility (EMC) – Part 3-6: Limits – Assessment of emission limits for the connection of distorting installations to MV, HV and EHV power systems;
 - IEC TR 61000-2-6:1995 Electromagnetic compatibility (EMC) - Part 2: Environment - Section 6: Assessment of the emission levels in the power supply of industrial plants as regards low-frequency conducted disturbances;
 - Nederlandse praktijkrichtlijn NPR-IEC/TR 61000-3-7:2008 (en) Electromagnetic compatibility (EMC) – Part 3-7: Limits – Assessment of emission limits for the connection of fluctuating installations to MV, HV and EHV power systems;
 - NEN-EN-IEC 61400-21-1:2019 (en) Wind energy generation systems – Part 21-1: Measurement and assessment of electrical characteristics – Wind turbines, paragraph 8.2: Power quality aspects;
 - NPR-IEC/TR 61400-21-3:2019 (en) Wind energy generation systems - Measurement and assessment of electrical characteristics - Wind turbine harmonic model and its application.

The Generating Unit test report also applies to other active components, such as flexible alternating current (FACTS) devices, if these components actively contribute by means of control functions to:

- The fault-ride-through performance at the Connection Point;
- Short and long term operation during over and under frequency as well as over and under voltage.

The PGFO shall submit simulation studies in the form of a report to demonstrate compliance. In all cases the simulation studies must utilise models applicable to the SPGM, PPM or OPFM with proposed or actual parameter settings. Reports should be submitted in Dutch or English with all diagrams and graphs plotted clearly with legible axes and scaling provided to ensure any variations in

plotted values is clear. In all cases the simulation studies must be presented as function of time to demonstrate compliance with all applicable requirements.

3.8 Type B – D simulation model

Before granting the EON, the PGFO and the RSO must exchange data in advance. The RSO needs this "best available" data to include it in the base network model in order to execute preliminary simulations. Before granting the ION, the simulation (software) models shall be delivered by the PGFO. Before granting the FON, the simulation models shall be updated with as-built data and validated with test results.

To perform grid stability calculations, information according Netcode elektriciteit article 13.1 and 13.2 shall be delivered for EON/ION, as a result of that:

- For type B PGM connected to the transmission-connected closed distribution system:
 - the simulation model should be adequate to simulate the load flow and short-circuit behaviour and the LFSM-O function as referred to in RfG articles 51(2) and 54(2);
 - the simulation model is validated against the compliance test for LFSM-O response;
- For types C or D PGM and for OPPM:
 - Full detail simulation model of the PGM up to the Connection Point, including individual Generating Units, transformers, inter-array cabling (in case of a PPM or OPPM), step-up transformer(s), high voltage cables, reactive power compensation equipment (if any), FACTS (if any), and PGM controllers and other active component;
 - For SPGM:
 - Dynamic simulation models of exciter, governor, power system stabiliser and any other limiters or controls shall be described by means of generic terms and parameters given by IEC and IEEE series
 - For PPM and for OPPM:
 - Full detail simulation model of Generating Unit and PPM controller and any other active component for load flow, short-circuit, harmonic (up to the 50th harmonic order) (only for type D) and dynamic simulations including manual and model controller settings to be applied shall be supplied;
 - Aggregation of Power-Generating Facility for the simulation model:
 - the power flow simulation models, fault current simulation models and dynamics simulation models of each Power-Generating Facility shall be delivered as an entity compiled into a minimum number of single equivalent generators;
 - the model shall cover – alongside the equivalent generators – the transformers needed to connect the generators and the Power-Generating Facility to the power system;
 - this aggregation level should be adequate for the optimal use of the dynamic simulation models for Generating Unit controller and PGM controller;
 - the aggregated model shall be described by means of generic terms and parameters given by IEC 61400-27 series;
 - All models shall be delivered in latest versions of both PSS/E and PowerFactory format;
 - Report on validation of simulation models shall be supplied.

- More specifically, the type of PPM models of type C and D and reports that need to be delivered for each model are shown in the table below. Detail requirements can be found in Annex: Requirements for RMS Simulation models.

Models	Generating Unit (GU) and controller model	Documents/Reports
Full detail PowerFactory simulation model (of PPM)	User defined GU and PPM controller model	The dynamic study should be delivered based on this model
Full detail PSS/E simulation model (of PPM)	User defined GU and PPM controller model	Benchmarking report of the PSS/E model based on the results of the full detail PowerFactory model for certain study cases (to be agreed with the PGFO)
Aggregated PowerFactory simulation model (of PPM)	Generic GU and PPM controller model (IEC models).	Benchmarking report of the PowerFactory aggregated model based on the results of the full detail PowerFactory model for certain study cases (to be agreed with the PGFO)
Aggregated PSS/E simulation model (of PPM)	Generic GU and PPM controller model (WECC models) ¹ .	Benchmarking report of the PSS/E aggregated model based on the results of the full detail PowerFactory model for certain study cases (to be agreed with the PGFO)

Validation of the simulation models is a responsibility of the PGFO. Validation can be done by the PGFO himself or by an external expert (manufacturer, consultant). Model validation of wind energy generation systems is the draft for IEC 61400-27-2. Model validation of other energy driven systems is expected to follow the same procedure. The PGFO should deliver validation reports of the generating unit model where the simulation results are compared with measurements. For type C and D PGMs, validation reports of both the PowerFactory and the PSS/E generating unit models are required. For type B PGMs connected to transmission-connected closed distribution system, validation reports of either the PowerFactory or the PSS/E generating unit models are required.

- For type D PGM: electromagnetic transient (EMT) models should also be delivered. Detail requirements can be found in Annex: Requirements for EMT Simulation models.

Evaluation criteria

- Models are delivered as described in this paragraph;
- Models will be checked related to data consistency and correct working in the RSO-grid model context.

¹ Western Electricity Coordinating Council. These generic models are reduced-order, positive-sequence models suitable for transmission planning studies; the link: <https://www.wecc.org/Pages/home.aspx>

4. Grid connection of generators (RfG)

4.1 RfG compliance

The compliance monitoring (CM) requirements are specified in the EU Regulation 2016/631 (NC RfG) in the articles following Title IV Compliance: Chapter 1 – Compliance monitoring. The compliance testing (CT) and compliance simulation (CS) requirements are specified in EU Regulation 2016/631 (NC RfG) in the articles following Title IV Compliance: Chapters 2-7 – Compliance testing & simulations. RfG Articles 40 to 43 inclusive are about the responsibilities and tasks, in short:

- It is the responsibility of the power-generating facility owner to ensure compliance throughout the lifetime of their equipment. The Power-Generating Facility Owner may rely upon equipment certificates
- CM procedures are the responsibility of the RSO and TSO
- Justification of validity of the applied equipment certificates is a part of the CM activity
- The power-generating facility owner is responsible for carrying out the tests in accordance with the conditions laid down in Chapters 2, 3 and 4 of RfG Title IV
- To demonstrate compliance with the requirements of this Regulation, the power-generating facility owner shall provide a report with the simulation results for each individual power-generating module within the power-generating facility
- The power-generating facility owner shall produce and provide a validated simulation model for a given power-generating module. Validation can be done by the PGFO himself or by an external expert (manufacturer, consultant). Model validation of wind energy generation systems is the draft for IEC 61400-27-2. Model validation of other energy driven systems is expected to follow the same procedure.
- The relevant system operator shall provide the power-generating facility owner with technical data and a simulation model of the network, to the extent necessary to carry out the requested simulations in accordance with Chapter 5, 6 or 7 of RfG Title IV.

The following table summarises the requirements against which testing and simulation are to be carried out in fulfilment of the requirements of the RfG code.

RfG require- ment	Requirement	SPGM / PPM	Testing					Simulations				
			Article	Type B	Type C	Type D	Off- shore	Article	Type B	Type C	Type D	Off- shore
13.1	Frequency range	PPM	1)	x	x	x	x					
13.2	LFSM-O	SPGM	44.2	x	x	x		51.2	x	x	x	
13.2	LFSM-O	PPM	47.3	x	x	x	x	54.2	x	x	x	x ¹⁾
15.2.c	LFSM-U	SPGM	45.2		x	x		52.2		x	x	
15.2.c	LFSM-U	PPM	48.3		x	x	x	55.2		x	x	x ¹⁾
15.2.d	FSM	SPGM	45.3		x	x		52.3		x	x	
15.2.d	FSM	PPM	48.4		x	x	x	55.3		x	x	x ¹⁾
15.2.e	Frequency restoration	SPGM	45.4		x	x						
15.2.e	Frequency restoration	PPM	48.5		x	x	x					
15.5.a	Black-start capability	SPGM	45.5		x	x		1)		x	x	
15.5.c	Tripping to houseload	SPGM	45.6		x	x						
16.2	Voltage range	SPGM	1)			x						
16.2	Voltage range	PPM	1)	x	x	x						
25.1	Voltage range	PPM	1)				x					
18.2.b/c	Reactive power capability	SPGM	45.7	x	x	x		52.5	x	x	x	
21.3.b/c	Reactive power capability	PPM	48.6	x	x	x	x	55.6	x	x	x	x
15.2.a	Active power controllability	PPM	48.2		x	x	x					
21.3.d	Voltage control mode (V1-mode and V2-mode)	PPM	48.7		x	x	x					
21.3.d	Reactive power control mode	PPM	48.8		x	x	x					
21.3.d	Power factor control mode	PPM	48.9		x	x	x					
15.5.b	Island operation	SPGM						52.4		x	x	
15.5.b	Island operation	PPM						55.4		x	x	x
14.3.a	Fault-Ride-Through type B	SPGM						51.3	x			
14.3.a	Fault-Ride-Through type C	SPGM						51.3		x		
14.3.a	Fault-Ride-Through type B	PPM	1)	x			x	54.4	x			x
14.3.a	Fault-Ride-Through type C	PPM	1)		x		x	54.4		x		x
16.3.a	Fault-Ride-Through type D	SPGM	1)			x		53.3			x	
16.3	Fault-Ride-Through type D	PPM	1)			x	x	56.3			x	x
14.4	Reconnecting after disconnection	SPGM	1)	x	x	x						
14.4	Reconnecting after disconnection	PPM	1)	x	x	x	x					
17.3	Post fault active power recovery	SPGM						51.4	x	x	x	
20.3	Post fault active power recovery	PPM						54.5	x	x	x	x
19.2	Power Oscillation Damping Control	SPGM						53.2			x	
21.3.f	Power Oscillation Damping Control	PPM						55.7		x	x	x
20.2.b	Fast fault current injection	PPM	1)	x	x	x	x	54.3	x	x	x	x
21.2.a	Synthetic inertia	PPM						55.5		x	x	x
NC 2.15	Power quality: rapid voltage change, flicker emissions, harmonics	PPM	1)			x	x	1)			x	x
NC 2.13	Insulation coordination	SPGM						1)			x	
NC 2.13	Insulation coordination	PPM						1)			x	x

1) required by RSO; not according to RfG

The tests apply to the complete PGM. If a test cannot be carried out at the Connection Point, e.g., if the function does not exist at PGM control level or the PGM is too large for existing testing facilities, the on-site test shall be carried out for a representative sample of each GU type to be installed in the PPM or a reasonable alternative test for an SPGM.

In the case of a PGM type B the following simplifications may be applied:

- Tests at site are not mandatory for PGM with Pmax below 5MW. The tests at site that are mandatory for a PGM with Pmax of 5 MW and above are:
 - LFSM-O
 - Reactive power capability
 - Reconnection after disconnection
- Regarding fault-ride-through, fast fault current injection and post fault active power recovery: generating units are type tested on these requirements; if for these requirements unit certificates are available for all generating units in the PGM, simulations to prove compliance with these requirements will not be required by the RSO.
- Regarding LFSM-O: generating units and PGM (park) controller are type tested on these requirements; if for these requirements unit certificates are available for all generating units and the (park) controller in the PGM, simulations to prove compliance with LFSM-O requirements will not be required by the RSO.

In the case of a PGM type B of which each Generating Unit is only controlled by an individual Generating Unit controller and not by a PGM (park) controller, a number of simplifications may be applied:

- Regarding reactive power capability, if for this requirement certificates are available for all generating units and other dynamically active components in the PGM, these may be used together with load flow based network calculations to prove the PGM reactive power capability at the connection point; in that case the on-site test for PGM with $P_{max} \geq 5\text{MW}$ will not be required by the RSO;
- Regarding LFSM-O: generating units are type tested on these requirements; if for these requirements unit certificates are available for all generating units in the PGM, simulations to prove compliance with these requirements will not be required by the RSO.

In the case of a PGM type D the following simplifications may be applied:

- When Pmax of the PGM is below 10 MW and Pmax is below 50% of the Connection capacity, the tests at site can be limited to those site tests required for Type B PGM

Type tests may be performed either by an independent test institute, by the PGFO or by the manufacturer. If the type tests are performed by the PGFO or the manufacturer, they need to be witnessed and approved by an independent test institute.

Simulation of the performance of individual Power-Generating Modules within a Power-Generating Facility shall aim at demonstrating that the requirements of this Regulation have been fulfilled. The scope of the PGM's simulation models is set out in point (c) of RfG Article 15(6). The level of detail of the network depends on the impact of the PGM on the stability of the power system and on the behaviour of other PGM's.

General requirements with regard to instrumentation are specified by RfG article 15(6), sub (b). General requirements with regard to simulation models are specified by RfG article 15(6), sub (c). RfG Article 15 specifies general requirements for type C (and cumulative for type D) Power-Generating Modules. RfG article 32 states that simulation models may be requested for type C PGM's to be included in the PGMD. The same article states that for both types B and C the results of simulation studies demonstrating steady-state and dynamic performance as required by RfG Chapters

5, 6 or 7 of Title IV, should be included. So, for both types B and C simulation studies have to be carried out and reported, but for type C also the models should be included in the PGMD. For type D, both simulation studies and the models should be reported.

Other general remarks regarding the compliance activities:

- A standard review sheet and overall dashboard, issued by the RSO, shall be used.
- Actual planning information shall be sent by the PGFO (Power-Generating Facility Owner) to the RSO during the entire compliance process.
- The PGFO is responsible to demonstrate compliance regarding the mentioned requirements. Unless stated otherwise, compliance tests, simulations and audits shall apply at the Connection Point. In addition to these tests and simulations, the PGFO shall deliver the structural data according to chapter 13 of the Netcode elektriciteit.
- The PGFO is responsible for the on-site tests, PQ-measurements, simulations and technical specifications. The PGFO shall prepare procedures for the tests for approval to the RSO, including expected active- and reactive power exchanges at the Connection Point, ultimately six weeks before the scheduled date for the on-site tests. The RSO will accept or comment the procedures ultimately three weeks before the scheduled date for the on-site tests.
- After approval of the test procedures by the RSO and at least two weeks before the commencement of the test, the PGFO shall provide the RSO with preliminary test dates. Final test dates shall be jointly agreed upon. PGFO shall invite the RSO for witnessing of the tests with a minimum of two calendar weeks' notice.
- Test reports shall be submitted to the RSO for approval within four weeks after the test has been performed.
- After receipt of each required report as mentioned in the previous paragraphs, the RSO will inform the PGFO within four weeks on approval of the reports. In case a revision of the report is required, the RSO will inform the PGFO within two weeks after receipt of the revised report.
- After as built values are measured, new simulations with the as built values are to be executed if necessary. The PGFO may submit a motivation to the RSO why execution of the simulations with the as built values is not necessary. Upon receipt of such a motivation the RSO will give a final decision regarding the necessity of new simulations.
- The RSO may involve a third party as its representative for the compliance activities (review of procedures, test reports, specifications, simulation studies, statements of compliance, verification of simulation models and witnessing of tests). The RSO will issue the formal notifications (EON, ION, FON).

The following paragraphs describe the details of all tests and simulations for SPGM and PPM of types B to D and for OPPM. Application of the tests and simulations depends on the type of PGM. The next table can be used as a reading/application guide with reference to paragraph 4.2

Sub-paragraph	Requirement	SPGM				PPM				OPPM
		A	B	C	D	A	B	C	D	
1	LFSM-O	x	x	x	x	x	x	x	x	x
2	LFSM-U			x	x			x	x	x
3	FSM			x	x			x	x	x
4	Frequency restoration			x	x			x	x	x
5	Black start capability			x	x					
6	Tripping to houseload			x	x					
7	Frequency range and Voltage range	x	x	x	x	x	x	x	x	x
8	Reactive power capability		x	x	x		x	x	x	x
9	Active power controllability							x	x	x
10	Voltage control mode							x	x	x
11	Reactive power control mode							x	x	x
12	Power factor control mode							x	x	x
13	Island operation			x	x			x	x	x
14	FRT (profiles different B/C and D)		x	x	x		x	x	x	x
15	Reconnecting after disconnection		x	x	x		x	x	x	x
16	Post fault active power recovery		x	x	x		x	x	x	x
17	Power Oscillation Damping Control (POD)				x			x	x	x
18	Fast fault current injection						x	x	x	x
19	Synthetic inertia							x	x	x
20	Power quality: voltage fluctuations, harmonics								x	x
21	Insulation coordination								x	x

4.2 RfG compliance testing and simulation for PGM

4.2.1 Requirement: LFSM-O

Applicable to:

SPGM	PPM	OPPM	Type A	Type B	Type C	Type D
------	-----	------	--------	--------	--------	--------

RfG article: 13(2)

Netcode elektriciteit article: 3.13, sub 4

Test: RfG article 44(2) (SPGM), 47(3) (PPM, OPPM)

Simulation: RfG article 51(2) (SPGM), 54(2) (PPM), OPPM: required by RSO; not according to RfG

Requirement to be verified.

RfG Article 13(2):

- (a) the Power-Generating Module shall be capable of activating the provision of active power frequency response according to figure 4.4 (RfG figure 1) at a frequency threshold and droop settings specified by the relevant TSO;
- (b) instead of the capability referred to in paragraph (a), the relevant TSO may choose to allow within its control area automatic disconnection and reconnection of power-generating modules of Type A at randomised frequencies, ideally uniformly distributed, above a frequency threshold, as determined by the relevant TSO where it is able to demonstrate to the relevant regulatory authority, and with the cooperation of power-generating facility owners, that this has a limited cross-border impact and maintains the same level of operational security in all system states;
- (c) the frequency threshold shall be between 50.2 Hz and 50.5 Hz inclusive;
- (d) the droop settings shall be between 2 % and 12 %;
- (e) the power-generating module shall be capable of activating a power frequency response with an initial delay that is as short as possible. If that delay is greater than two seconds, the power-generating facility owner shall justify the delay, providing technical evidence to the relevant TSO;
- (f) the relevant TSO may require that upon reaching minimum regulating level, the power-generating module be capable of either:
 - (i) continuing operation at this level; or
 - (ii) further decreasing active power output;
- (g) the power-generating module shall be capable of operating stably during LFSM-O operation. When LFSM-O is active, the LFSM-O setpoint will prevail over any other active power setpoints.

From Netcode elektriciteit Article 3.13, sub 4:

- (a) the frequency threshold can be set to a value between 50.2 Hz and 50.5 Hz;
- (b) the frequency threshold will be set to: 50.2 Hz;
- (c) the droop setting is adjustable between 4% and 12%;
- (d) the default droop is: 5%;
- (e) upon reaching the minimum regulating level, the Power-Generating Module must be

capable of continuing operation at this level;

- (f) in case of a PPM, P_{ref} , as mentioned in figure 4.4 (RfG figure 1), is equal to the actual active power at the moment the LFSM-O threshold is reached.

ENTSO-E recommends the following values for the maximum settling time (Limited frequency sensitive mode; ENTSO-E guidance document for national implementation for network codes on grid connection; 31 January 2018):

- active power decrease in case of increasing frequency during LFSM-O/-U activation:
 - Synchronous power generating modules: ≤ 30 s
 - Power Park Modules: ≤ 20 s
- active power increase in case of decreasing frequency during LFSM-O/-U activation:
 - Synchronous power generating modules: ≤ 6 min
 - Power Park Modules: ≤ 30 s

According to Netcode elektriciteit Article 3.13, sub 4, the PGM shall be capable of continuing operation at its minimum regulating level. So, the active power response shall be provided during the time the frequency is above the threshold value.

Policy on Emergency and Restoration (ENTSO-E, 15.02.2022)

C-4-3 Frequency deviation management before frequency leader nomination – Activation of Limited Frequency Sensitive Mode (LFSM)

In case of LFSM is activated, the FCR providing units' or FCR providing groups' LFSM response shall resume from the overall FCR activation as of LFSM intervention. In such a scenario, the FCR providing unit or group shall cumulatively activate its LFSM provision starting from the last FCR set-point calculated at the LFSM triggering.

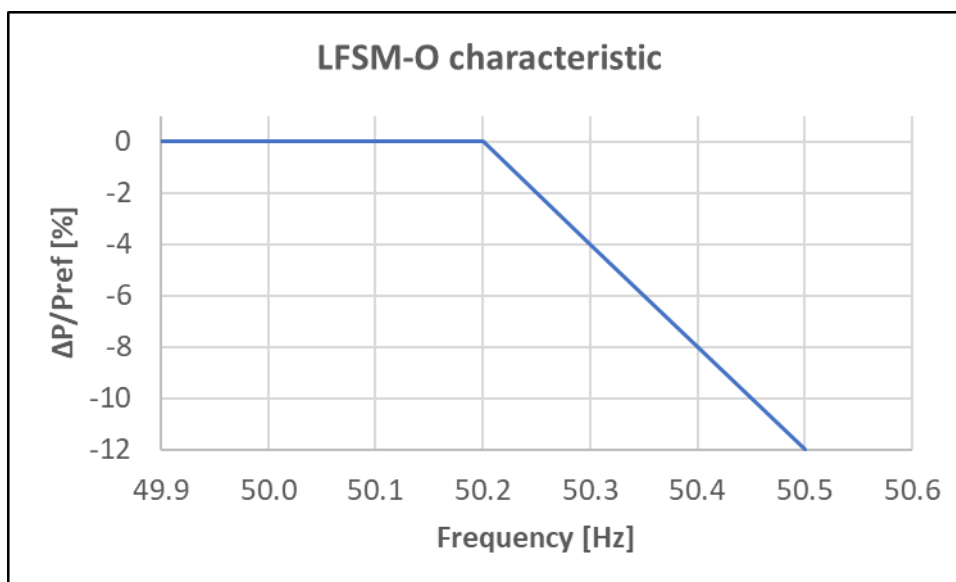

Figure 4.4 Active power frequency response capability of Power-Generating Modules in LFSM-O with droop 5% (RfG figure 1)

The relation between frequency, droop and active power change is:

$$\Delta f = \Delta f_1 - \frac{s_2}{100} \cdot \frac{\Delta P/P_{ref}}{100} \cdot f_n \text{ [Hz]}$$

Or

$$\Delta P/P_{ref} = \frac{\Delta f_1 - \Delta f}{f_n} \cdot \frac{100}{s_2} \cdot 100 \text{ [%]}$$

With:

- s_2 : LFSM-O frequency droop [%]
- f_n : nominal frequency: 50 Hz
- f_1 : LFSM-O frequency threshold: 50.2 Hz
- Δf_1 : frequency deviation threshold: $\Delta f_1 = f_1 - f_n$
- Δf : frequency deviation to obtain the desired active power change [Hz]
- $\Delta P/P_{ref}$: change in active power output from the power-generating module [%]
as a proportion of P_{ref}

In case of an SPGM P_{ref} , as mentioned in figure 4.4 (RfG figure 1), is the maximum capacity.

In case of a PPM P_{ref} is equal to the actual active power at the moment the LFSM-O threshold is reached.

The formula is only valid if the frequency deviation is larger than or equal to the frequency deviation threshold: $\Delta f \geq \Delta f_1$.

For example, to obtain 8% active power change at a droop setting of 5% and an actual frequency of 50 Hz during test, the frequency change should be 0.4 Hz (0.2 Hz for threshold plus 0.2 Hz).

Objective

- The Power-Generating Facility Owner (PGFO) shall demonstrate the Power-Generating Module's technical capability to continuously modulate active power to contribute to frequency control in case of any large increase of frequency in the system;
- The steady-state parameters of controls (such as droop and the power-frequency control threshold value²) and dynamic parameters, including frequency step change response shall be verified.

LFSM-O tests

Test procedure

The PGM must be in operation and connected with the network.

² RfG article 44(2) refers to the deadband. In the second objective the threshold value is considered as deadband.

The test will be carried out by simulating frequency steps and frequency ramps at the PGM's control input which are sufficiently large to initiate at least 10% of the Maximum Capacity change of the active power, taking into account the droop settings. The frequency shall be varied over the full range from 50.0 Hz to 51.5 Hz. After each frequency step or ramp the PGM should maintain the new operating point for at least 15 minutes (SPGM) or 2 minutes (PPM and OPPM) and until the PGM active power output has stabilised.

As stated in Netcode elektriciteit article: 3.13, sub 4, the LFSM-O activates above a frequency threshold of 50.2 Hz. The droop shall be set to 5%. At 5% droop a frequency change of 200 mHz above the threshold should cause a change of active power equal to 8% of P_{ref} at the start of the test. This corresponds to 40% P_{ref} per Hz.

The test should be performed with curtailed power so that P_{ref} is the same between 50 Hz and 50.2 Hz. In this way it is assured that the changes in active power is only due to frequency variations and not due to primary resource changes.

For the performance of the test, there should be no frequency response between 49.8 Hz and 50.2 Hz , so that the provision of primary and secondary control power shall be deactivated.

Operating point:

- The tests shall be carried out for an initial operating point between the PGM's Minimum Regulating Level and its Maximum Capacity from which it will be possible to test at least 15% active power decrease. The operating point will be determined in consultation with the RSO. For SPGM the operating point will be 70% of the Maximum Capacity. For a PPM the operating point shall be minimum 60% of the Maximum Capacity.

A frequency step response test will be carried out according to the following sequences:

Starting frequency (Hz)	To frequency (Hz)	Power change per step
50.0	50.2	0%
50.2	50.5	-12%
50.5	51.0	-20%
51.0	51.5	-20%
51.5	51.0	+20%
51.0	50.5	+20%
50.5	50.2	+12%
50.2	50.0	0%

Refer to figure 4.5.

The power change is in % of P_{ref} . The new power output may be limited by the Minimum Regulating Level.

After each frequency step:

- the initial delay time shall be as short as possible;
- the maximum settling time in case of increasing frequency must be: 30 s (SPGM); 20 s (PPM and OPPM);
- the maximum settling time in case of decreasing frequency must be: 6 min (SPGM); 30 s (PPM and OPPM);
- hold until conditions stabilise;
- the PGM shall maintain the new operating point for at least 15 minutes (SPGM); 2 minutes (PPM and OPPM).

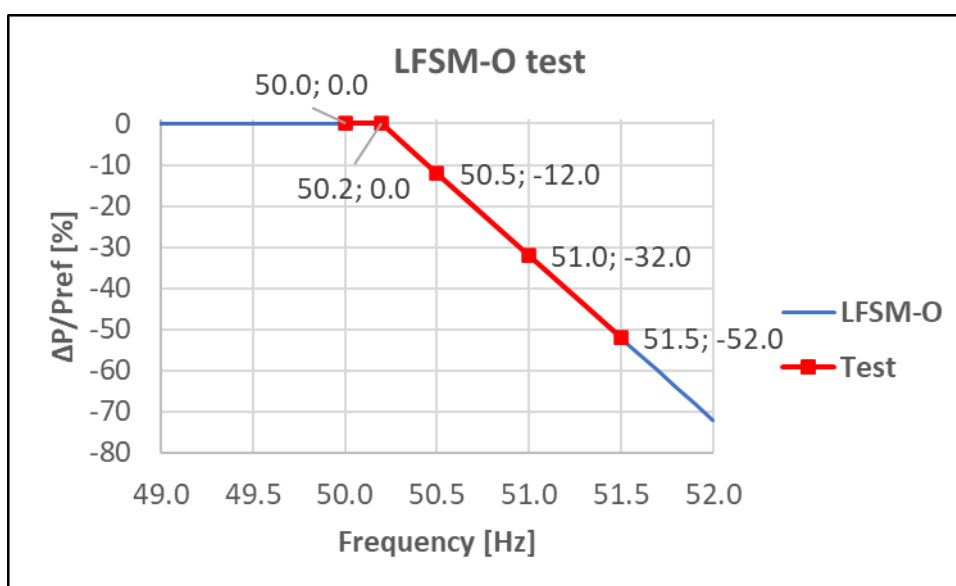

Figure 4.5 LFSM-O test points corresponding to 5% droop

The frequency response test will be repeated for frequency ramps with gradients of 0.2 Hz per minute (at 5% droop 8% P_{ref} per minute).

Documentation/measurements

- The simulated frequency, P, Q, V shall be measured as function of the time at the Connection Point; all will be recorded on the same time scale;
- Applied settings of PGM and GU controller including frequency droop setting;
- A tolerance band of max. +/- 5% of the measured value will be accepted.

Test evaluation criteria

The test shall be deemed successful if the following conditions are fulfilled:

- The PGM has not tripped as a consequence of the test during or after the test
- The frequency threshold is 50.2 Hz
- The active power response to a frequency rise at or above 50.2 Hz is according to

the droop setting

- The initial delay time shall be as short as possible; if the initial response time is beyond 2 s, the PGFO has to offer a reasonable justification to the RSO
- The settling time is maximum 30 s (SPGM) or 20 s (PPM and OPPM)
- The PGM maintains each new operating point for 15 minutes (SPGM) or 2 minutes (PPM and OPPM) after each frequency step and frequency ramp
- Undamped oscillations do not occur after the step change response.

LFSM-O Simulations

Regarding LFSM-O, generating units are type tested on this requirement. In case of a PPM type B of which each Generating Unit is only controlled by an individual Generating Unit controller and not by a PGM (park) controller, if for this requirement certificates are available for all dynamically active equipment in the PPM, simulations to prove compliance with this requirement will not be required by the RSO. In case of a PGM (park) controller, the simulations are always required. The control settings shall be specified to the RSO.

Simulation procedure

The simulation will be carried out by simulating frequency steps and frequency ramps which are sufficiently large to reduce the active power output to the PGM's Minimum Regulating Level.

As stated in Netcode elektriciteit article: 3.13, sub 4, the LFSM-O activates above a frequency threshold of 50.2 Hz. The droop setting is 5%. A frequency change of 200 mHz above the threshold should cause a change of active power equal to 8% of the Maximum Capacity (SPGM) or 8% of P_{ref} (PPM, OPPM).

The initial starting point of the simulations are the same as in the tests.

- The simulations shall cover the tests for the PGM and prove the validity of the simulation model
- The simulations will be carried out for the same operating point as was used in the test
- A frequency step simulation will be carried out:
 - Starting at 50.0 Hz injection of a frequency step of +200 mHz at the PGM's control input;
 - followed by injection of a frequency step of +300 mHz at the PGM's control input, causing the PGM's active power to decrease by 12% of P_{ref} ;
 - followed by injection of a frequency step of +500 mHz at the PGM's control input, causing the PGM's active power to decrease by 20% of P_{ref} ;
 - followed by injection of a frequency step of +500 mHz at the PGM's control input, causing the PGM's active power to decrease by 20% of P_{ref} ;
 - followed by the reverse frequency steps to 50.0 Hz;
- A frequency ramp simulation will be carried out:

- Starting at 50.0 Hz injection of a frequency ramp from 0 mHz to +200 mHz at 0.2 Hz per minute at the PGM's control input;
- followed by injection of a frequency ramp from 0 mHz to +300 mHz at 0.2 Hz per minute at the PGM's control input, causing the PGM's active power to decrease by 12% of P_{ref} ;
- followed by injection of a frequency ramp from 0 mHz to +500 mHz at 0.2 Hz per minute at the PGM's control input, causing the PGM's active power to decrease by 20% of P_{ref} ;
- followed by injection of a frequency ramp from 0 mHz to +500 mHz at 0.2 Hz per minute at the PGM's control input, causing the PGM's active power to decrease by 20% of P_{ref} ;
- followed by the reverse frequency ramps to 50.0 Hz.

Simulation evaluation criteria

The simulation shall be deemed successful if the following conditions are fulfilled:

- The frequency threshold is 50.2 Hz
- The SPGM active power response to frequency rise above 50.2 Hz is according to the droop setting until the Minimum Regulating Level is reached
- The PPM and OPPM active power response to frequency rise above 50.2 Hz is according to the droop setting until the Minimum Regulating Level is reached
- The initial delay time shall be as short as possible; if the initial response time is beyond 2 s, the PGFO has to offer a reasonable justification to the RSO
- The settling time is maximum 30 s (SPGM) or 20 s (PPM)
- The simulation model of the Power Park Module is validated against the compliance test for LFSM-O response by expert judgement
- Undamped oscillations do not occur after the step change response.

4.2.2 Requirement: LFSM-U

Applicable to:

SPGM	PPM	OPPM			Type C	Type D
------	-----	------	--	--	--------	--------

RfG article: 15(2)(c)

Netcode elektriciteit article: 3.24, sub 2

Test: RfG article 45(2) (SPGM), 48(3) (PPM, OPPM)

Simulation: RfG article 52(2) (SPGM), 55(2) (PPM), OPPM: required by RSO; not according to RfG

Requirement to be verified

RfG Article 15(2)(c):

In addition to Article 13(2), the following requirements shall apply to type C power-generating modules with regard to limited frequency sensitive mode - underfrequency (LFSM-U):

- (i) the Power-Generating Module shall be capable of activating the provision of active power frequency response at a frequency threshold and with a droop specified by the relevant TSO in coordination with the TSOs of the same synchronous area as follows:
 - the frequency threshold specified by the TSO shall be between 49.8 Hz and 49.5 Hz inclusive,
 - the droop settings specified by the TSO shall be in the range 2-12 %.This is represented graphically in [RfG] figure 4;
- (ii) the actual delivery of active power frequency response in LFSM-U mode shall take into account:
 - ambient conditions when the response is to be triggered,
 - the operating conditions of the Power-Generating Module, in particular limitations on operation near maximum capacity at low frequencies and the respective impact of ambient conditions according to paragraphs 4 and 5 of [RfG] Article 13, and
 - the availability of the primary energy sources.
- (iii) the activation of active power frequency response by the Power-Generating Module shall not be unduly delayed. In the event of any delay greater than two seconds, the Power-Generating Facility Owner shall justify it to the relevant TSO;
- (iv) in LFSM-U mode the Power-Generating Module shall be capable of providing a power increase up to its maximum capacity;
- (v) stable operation of the Power-Generating Module during LFSM-U operation shall be ensured;

P_{ref} is the reference active power to which ΔP is related and may be specified differently for synchronous power-generating modules and power park modules. ΔP is the change in active power output from the power-generating module. f_n is the nominal frequency (50 Hz) in the network and Δf is the frequency deviation in the network. At underfrequencies where Δf is below Δf_1 the power-generating module has to provide a positive active power output change according to the droop S_2 .

From Netcode elektriciteit Article 3.24, sub 2:

- (a) the frequency threshold can be set to a value between 49.5 Hz and 49.8 Hz;
- (b) the frequency threshold will be set to: 49.8 Hz;
- (c) the droop setting is adjustable between 4% and 12%;
- (d) the default droop is: 5%;
- (e) in case of a PPM, P_{ref} , as mentioned in figure 4.6 (RfG figure 4), is equal to the actual active power at the moment the LFSM-U threshold is reached.

ENTSO-E recommends the following values for the maximum settling time (Limited frequency sensitive mode; ENTSO-E guidance document for national implementation for network codes on grid connection; 31 January 2018):

- active power decrease in case of increasing frequency during LFSM-O/-U activation:
 - Synchronous power generating modules: ≤ 30 s
 - Power Park Modules: ≤ 20 s
- active power increase in case of decreasing frequency during LFSM-O/-U activation:
 - Synchronous power generating modules: ≤ 6 min
 - Power Park Modules: ≤ 30 s

The minimum duration of providing the full active power response after a frequency change shall take into account the availability of the primary energy source.

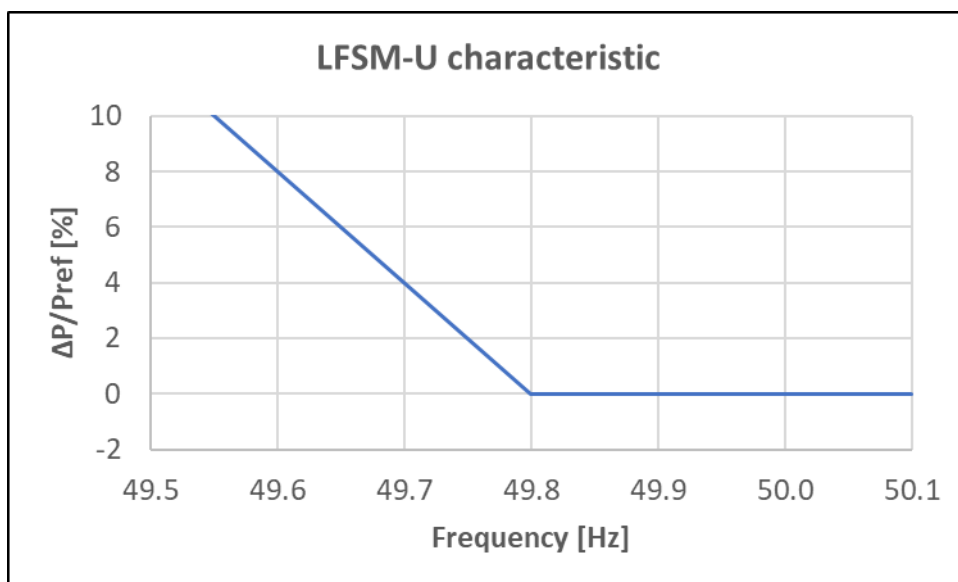

Figure 4.6 Active power frequency response capability of Power-Generating Modules in LFSM-U with droop 5% (RfG figure 4)

The relation between frequency, droop and active power change is:

$$\Delta f = \Delta f_1 - \frac{s_2}{100} \cdot \frac{\Delta P/P_{ref}}{100} \cdot f_n \text{ [Hz]}$$

Or

$$\Delta P/P_{ref} = \frac{\Delta f_1 - \Delta f}{f_n} \cdot \frac{100}{s_2} \cdot 100 \text{ [%]}$$

With:

- s_2 : LFSM-U frequency droop [%]
- f_n : nominal frequency: 50 Hz

- f_1 : LFSM-U frequency threshold: 49.8 Hz
- Δf_1 : frequency deviation threshold: $\Delta f_1 = f_1 - f_n$
- Δf : frequency deviation to obtain the desired active power change [Hz]
- $\Delta P/P_{ref}$: change in active power output from the power-generating module [%]
as a proportion of P_{ref}

In case of an SPGM, P_{ref} , as mentioned in figure 4.6 (RfG figure 4), is the maximum capacity.

In case of a PPM, P_{ref} is equal to the actual active power at the moment the LFSM-U threshold is reached.

The formula is only valid if the frequency deviation is lower than or equal to the frequency deviation threshold: $\Delta f \leq \Delta f_1$.

For example, to obtain 8% active power change at a droop setting of 5% and an actual frequency of 50 Hz during test, the frequency deviation should be -0.4 Hz (-0.2 Hz for threshold minus 0.2 Hz).

Objective

- The Power-Generating Facility Owner (PGFO) shall demonstrate the Power-Generating Module's technical capability to continuously modulate active power to contribute to frequency control in case of any large drop of frequency in the system;
- The steady-state parameters of regulations (such as droop and the power-frequency control threshold value³) and dynamic parameters, including frequency step change response shall be verified.

LFSM-U tests

Test procedure

The PGM must be in operation and connected with the network.

In case of an SPGM: the test shall be carried out by simulating appropriate active power load points, with low frequency steps and ramps big enough to trigger active power change of at least 10 % of maximum capacity, taking into account the droop settings and the frequency threshold. If required, simulated frequency deviation signals shall be injected simultaneously into both the speed governor and the load controller references.

In case of a PPM: the test shall be carried out by simulating the frequency steps and ramps big enough to trigger at least 10 % of maximum capacity active power change with a starting point of no more than 80 % of maximum capacity, taking into account the droop settings and the frequency threshold.

After each frequency step or ramp the PGM should maintain the new operating point for at least 15 minutes (SPGM) or 2 minutes (PPM and OPPM) and until the PGM active power output has stabilised.

³ RfG article 45(2) refers to the deadband. In the second objective the threshold value is considered as deadband.

As stated in Netcode elektriciteit article: 3.24, sub 2, the LFSM-U activates below a frequency threshold of 49,8 Hz. The droop shall be set to 5%. At 5% droop a frequency change of -200 mHz below the threshold should cause a change of active power equal to 10% of P_{ref} at the start of the test. This corresponds to 50% P_{ref} per Hz.

For the performance of the test, there should be no frequency response between 49.8 Hz and 50.2 Hz, so that the provision of primary and secondary control power shall be deactivated.

Operating point:

- The tests shall be carried out for an initial curtailed operating point between the PGM's Minimum Regulating Level and its Maximum Capacity from which it will be possible to test at least 12% active power increase. The operating point will be determined in consultation with the RSO. For SPGM the default operating point will be 55% of the Maximum Capacity. For a PPM the operating point shall be minimum 45% of the Maximum Capacity

A frequency step response test will be carried out according to the following sequences:

Starting frequency (Hz)	To frequency (Hz)	Power change
50.0	49.8	0%
49.8	49.5	+12%
49.5	49.8	-12%
49.8	50.0	0%

Refer to figure 4.7.

The power change is in % of P_{ref} . The new power output may be limited by the maximum available power output.

After each frequency step:

- the initial delay time shall be as short as possible;
- the maximum settling time in case of increasing frequency must be: 30 s (SPGM); 20 s (PPM and OPPM);
- the maximum settling time in case of decreasing frequency must be: 6 min (SPGM); 30 s (PPM and OPPM);
- hold until conditions stabilise;
- the PGM shall maintain the new operating point for at least 15 minutes (SPGM); 2 minutes (PPM and OPPM).

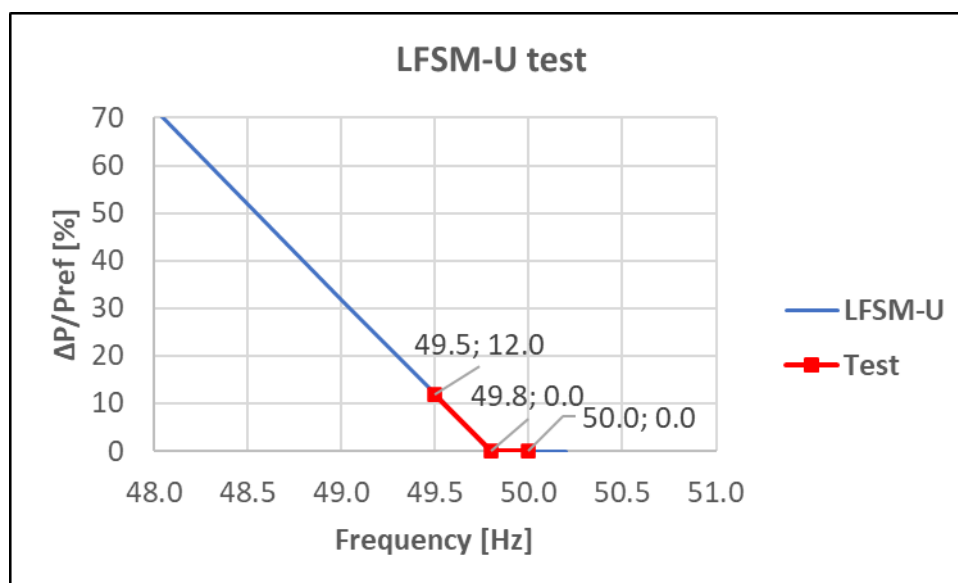

Figure 4.7 LFSM-U test points corresponding to 5% droop

The frequency response test will be repeated for frequency ramps with gradients of 0,2 Hz per minute (at 5% droop 8% P_{ref} per minute).

Documentation/measurements

- The simulated frequency, P, Q, V shall be measured as function of the time at the Connection Point; all will be recorded on the same time scale;
- Applied settings of PGM and GU controller including frequency droop setting;
- A tolerance band of max. +/- 5% of the measured value will be accepted.

Test evaluation criteria

The test shall be deemed successful if the following conditions are fulfilled:

- The PGM has not tripped as a consequence of the test during or after the test
- The frequency threshold is 49.8 Hz
- The active power response to a frequency drop at or below 49.8 Hz is according to the droop setting
- The initial delay time shall be as short as possible; if the initial response time is beyond 2 s, the PGFO has to offer a reasonably justification to the RSO
- The settling time is maximum 6 min (SPGM) or 30 s (PPM and OPPM)
- The PGM maintains each new operating point for a time that is technical feasible, taking into account the availability of the primary energy source, with a minimum of 15 minutes (SPGM) or 2 minutes (PPM and OPPM)
- Undamped oscillations do not occur after the step change response.

LFSM-U Simulations

Simulation procedure

The simulation will be carried out by simulating frequency steps and frequency ramps which are sufficiently large to increase the active power output to the PGM's Maximum Capacity (SPGM) or maximum available active power output (PPM).

As stated in Netcode elektriciteit article: 3.13, sub 4, the LFSM-U activates below a frequency threshold of 49.8 Hz. The droop setting is: 5%. A frequency change of -200 mHz below the threshold should cause a change of active power equal to 8% of the Maximum Capacity (SPGM) or P_{ref} (PPM).

- The simulations shall cover the tests for the PGM and prove the validity of the simulation model
- The simulations will be carried out for the same operating point as was used in the test
- A frequency step simulation will be carried out:
 - Starting at 50.0 Hz injection of a frequency step of -200 mHz at the PGM's control input;
 - followed by injection of a frequency step of -300 mHz at the PGM's control input, causing the PGM's active power to increase by 12% of P_{ref} ;
 - followed by the reverse frequency steps to 50.0 Hz;
- A frequency ramp simulation will be carried out:
 - Starting at 50.0 Hz injection of a frequency ramp from 0 mHz to -200 mHz at -0.2 Hz per minute at the PGM's control input;
 - followed by injection of a frequency ramp from 0 mHz to -300 mHz at -0.2 Hz per minute at the PGM's control input, causing the PGM's active power to increase by 12%;
 - followed by the reverse frequency ramps to 50.0 Hz.

Simulation evaluation criteria

The simulation shall be deemed successful if the following conditions are fulfilled:

- The frequency threshold is 49.8 Hz
- The droop is 5%
- The PGM active power response to frequency drop at or below 49.8 Hz is according to the droop setting until the Maximum Capacity has been reached
- The initial delay time shall be as short as possible; if the initial response time is beyond 2 s, the PGFO has to offer a reasonably justification to the RSO
- The settling time is maximum 6 min (SPGM) or 30 s (PPM)
- The simulation model of the Power Park Module is validated against the compliance test for LFSM-U response by expert judgement
- Undamped oscillations do not occur after the step change response.

4.2.3 FSM

Applicable to:

SPGM	PPM	OPPM			Type C	Type D
------	-----	------	--	--	--------	--------

RfG article: 15(2)(d)

Netcode elektriciteit article: 3.24, sub 3

Test: RfG article 45(3) (SPGM), 48(4) (PPM, OPPM)

Simulation: RfG article 52(3) (SPGM), 55(3) (PPM), OPPM: required by RSO; not according to RfG

Requirement to be verified

RfG Article 15(2)(d):

in addition to point (c) of paragraph 2, the following shall apply cumulatively when frequency sensitive mode ('FSM') is operating:

- (i) the power-generating module shall be capable of providing active power frequency response in accordance with the parameters specified by each relevant TSO within the ranges shown in [RfG] Table 4. In specifying those parameters, the relevant TSO shall take account of the following facts:
- in case of overfrequency, the active power frequency response is limited by the minimum regulating level,
 - in case of underfrequency, the active power frequency response is limited by maximum capacity,
 - the actual delivery of active power frequency response depends on the operating and ambient conditions of the power-generating module when this response is triggered, in particular limitations on operation near maximum capacity at low frequencies according to paragraphs 4 and 5 of [RfG] Article 13 and available primary energy sources;

Table 4 Parameters for active power frequency response in FSM (explanation for [RfG] Figure 5)

Parameters		Ranges
Active power range related to maximum capacity $ \Delta P_1 /P_{max}$		1.5 – 10 %
Frequency response insensitivity	$ \Delta f_i $	10 – 30 mHz
	$ \Delta f_i /f_n$	0.02 – 0.06 %
Frequency response deadband		0 – 500 mHz
Droop s_1		2 – 12 %

From Netcode elektriciteit Article 3.24, sub 3:

The Power-Generating Module shall be capable of providing active power frequency response in accordance with the parameters:

- (a) the active power range related to maximum capacity is: 1.5% to 10%;
- (b) the frequency response insensitivity is: 10 mHz;

- (c) the frequency response deadband is adjustable from 0 to 500 mHz;
- (d) the droop is adjustable from 4% to 12%;
- (e) in case of a PPM, P_{ref} , as mentioned in figure 4.8 (RfG figure 5), is equal to the actual active power at the moment the FSM threshold is reached.

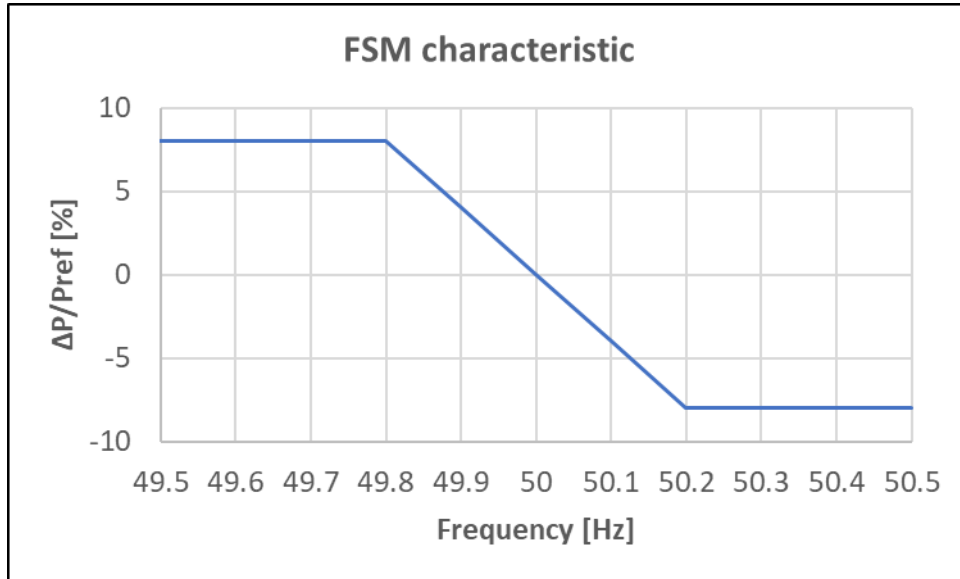

Figure 4.8 Active power frequency response capability of Power-Generating Modules in FSM illustrating the case of zero deadband and insensitivity with droop 5% (RfG figure 5)

The relation between frequency, droop and active power change is:

$$\Delta f = -\frac{s_1}{100} \cdot \frac{\Delta P/P_{ref}}{100} \cdot f_n \text{ [Hz]}$$

Or

$$\Delta P/P_{ref} = \frac{-\Delta f}{f_n} \cdot \frac{100}{s_1} \cdot 100 \text{ [%]}$$

With:

- s_1 : FSM frequency droop [%]
- f_n : nominal frequency: 50 Hz
- Δf : frequency deviation to obtain the desired active power change [Hz]
- $\Delta P/P_{ref}$: change in active power output from the power-generating module [%]
as a proportion of P_{ref}

In case of an SPGM, P_{ref} , as mentioned in figure 4.8 (RfG figure 5), is the maximum capacity.

In case of a PPM, P_{ref} is equal to the actual active power at the moment the FSM threshold is reached.

For the tests and simulations 5% droop will be set.

Delay time and time for full activation of frequency response

RfG Article 15(2)(d)(iv):

The initial activation of active power frequency response required shall not be unduly delayed.

If the delay in initial activation of active power frequency response is greater than two seconds, the power- generating facility owner shall provide technical evidence demonstrating why a longer time is needed.

For power-generating modules without inertia, the relevant TSO may specify a shorter time than two seconds. If the power-generating facility owner cannot meet this requirement they shall provide technical evidence demonstrating why a longer time is needed for the initial activation of active power frequency response;

Netcode elektriciteit article 3.24, sub 4, sub a:

The maximum time for full activation of frequency response is: $t_2 = 30$ s

In figure 4.9 (RfG figure 6) P_{max} is the maximum capacity to which ΔP relates. ΔP is the change in active power output from the Power-Generating Module. The Power-Generating Module has to provide active power output ΔP up to the point ΔP_1 in accordance with the times t_1 and t_2 with the values of ΔP_1 , t_1 and t_2 being specified by the relevant TSO:

- t_1 is the initial delay and is 2 s or more if justified in line with (EU) 2016/631
- t_2 is the time for full activation and is specified 30 s.

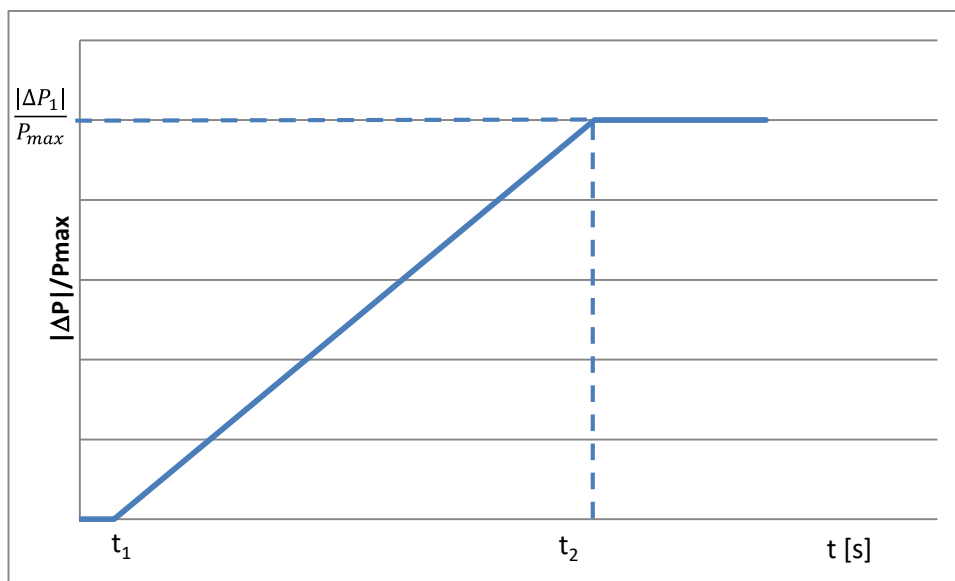

Figure 4.9 Active power frequency response capability (RfG figure 6)

RfG Article 15(2)(d)(v):

the power-generating module shall be capable of providing full active power frequency response for a period of between 15 and 30 minutes as specified by the relevant TSO. In specifying the period, the TSO shall have regard to active power headroom and primary energy source of the power-generating module;

Netcode elektriciteit article 3.24, sub 5:

The PGM shall be capable of providing full active power frequency response for a minimum period of 15 minutes (SPGM) or 2 minutes (PPM and OPPM) at each new operating point.

Objective

- The test shall demonstrate that the Power-Generating Module is technically capable of continuously modulating active power over the full operating range between Maximum Capacity and Minimum Regulating Level to contribute to frequency control.
- The steady-state parameters of regulations, such as droop and deadband and dynamic parameters, including robustness through frequency step change response and large, fast frequency deviations shall be verified.

FSM Tests

Test procedure

The PGM must be in operation and connected with the network.

The test shall be carried out by simulating frequency steps and ramps big enough to trigger the whole active power frequency response range, taking into account the settings of droop and deadband, as well as the capability to actually increase or decrease active power output from the respective operating point. The FSM will be effective at frequencies between the LFSM thresholds 49.8 Hz and 50.2 Hz⁴:

- In case of overfrequency, the active power frequency response is limited by the Minimum Regulating Level,
- in case of underfrequency, the active power frequency response is limited by Maximum Capacity,
- the actual delivery of active power frequency response depends on the operating and ambient conditions of the Power-Generating Module when this response is triggered, in particular limitations on operation near maximum capacity at low frequencies according to paragraphs 4 and 5 of Article 13 and available primary energy sources.

⁴ The FSM response is additional to the LFSM response and will not be effective in the frequency range in which the LFSM-O/U will be active.

After each frequency step or ramp the PGM should maintain the new operating point for at least 15 minutes (SPGM) or 2 minutes (PPM and OPPM) and until the PGM active power output has stabilised.

For this test, the frequency response deadband shall be 0 mHz and the droop shall be set to 5%. E.g. at 5% droop a frequency step change of 200 mHz corresponds with 8% active power response. For larger frequency step changes the LFSM-O/U will be active.

Operating point:

- The tests shall be carried out for an initial curtailed operating point between the PGM's Minimum Regulating Level and its Maximum Capacity from which it will be possible to test at least 10% active power increase. The operating point will be determined in consultation with the RSO. For SPGM the default operating point will be 70% of the Maximum Capacity. For a PPM the operating point shall be minimum 45% of the Maximum Capacity.

During the test we have three different P_{ref} values, one when entering FSM, one when entering LFSM-O and one when entering LFSM-U. This is also shown in table below.

Test 1: The following sequences will be executed, using a frequency signal at the PGM's control input:

Starting frequency (Hz)	To frequency (Hz)	Power change
50.0	50.1	-4% (of $P_{ref,FSM}$)
50.1	50.2	-4% (of $P_{ref,FSM}$)
50.2	50.3	-4% (of $P_{ref,LFSMO}$)
50.3	50.2	+4% (of $P_{ref,LFSMO}$)
50.2	50.0	+8% (of $P_{ref,FSM}$)
50.0	49.9	+4% (of $P_{ref,FSM}$)
49.9	49.8	+4% (of $P_{ref,FSM}$)
49.8	49.7	+4% (of $P_{ref,LFSMU}$)
49.7	49.8	-4% (of $P_{ref,LFSMU}$)
49.8	50.0	-8% (of $P_{ref,FSM}$)

Refer to figure 4.10.

The power change is in % of P_{ref} . The new power output may be limited by the maximum available power output or the Minimum Regulating Level.

The purpose of executing the test at frequencies above 50.2 Hz and below 49.8 Hz is to demonstrate the capability to successfully transit into the LFSM-O/U modes. The response depends on the LFSM-O/U settings. The power change values in the table assume that the LFSM-O/U droop settings are equal to the FSM droop setting.

At each sequence:

- After the step maintain the frequency until the active power output of the PGM has stabilized, but at least 15 minutes (SPGM); 2 minutes (PPM and OPPM);
- Record the initial delay time t_1 ;
- Record the time for full activation time t_2 of the frequency response.

Test 2: The frequency response test will be repeated for frequency ramps with gradients of 0.2 Hz per minute (corresponding to 8% P_{ref} per minute at 5% droop).

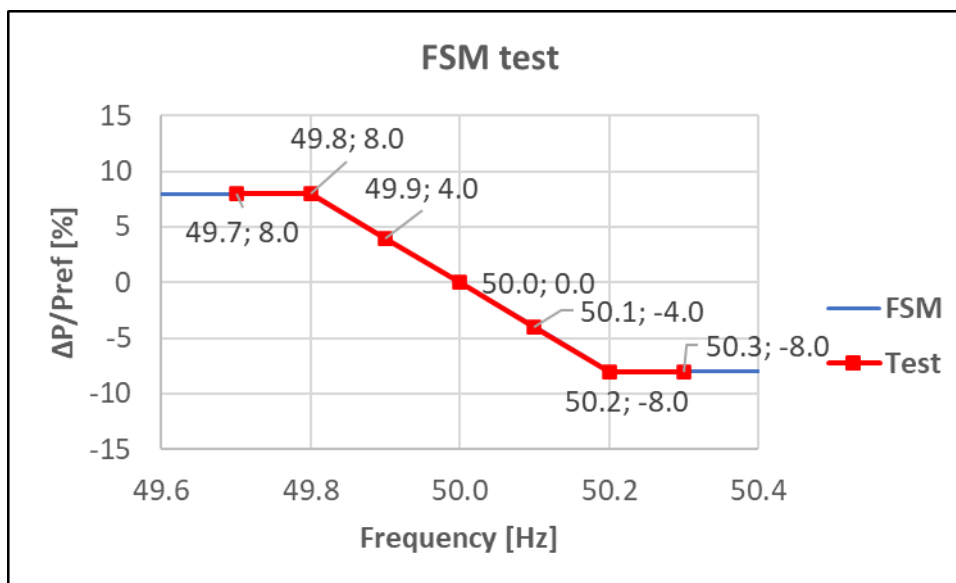

Figure 4.10 FSM test points corresponding to 5% droop

Documentation/measurements

- Maximum Capacity
- Active Power set point for each test
- The simulated frequency shall be measured as function of the time
- P, Q, V shall be measured as function of the time at the Connection Point;
- Record the initial delay time t_1 ;
- Record the time for full activation time t_2 of the frequency response;
- Applied settings of PGM and GU controller including frequency droop setting;
- A tolerance band of max. +/- 5% of the measured value will be accepted.

Test evaluation criteria

The test shall be deemed successful if the following conditions are fulfilled:

- the PGM has not tripped as a consequence of the test during or after the test
- the activation time of full active power frequency response range as a result of a frequency step change (Test 1) is no longer than 30 s (required by point (d)(iii) of

RfG Article 15(2) and Netcode elektriciteit Article 3.24, sub 4);

- the time lag of full active power frequency response as a result of a frequency ramp change (Test 2) is no longer than 30 s (required by point (d)(iii) of RfG Article 15(2) and Netcode elektriciteit Article 3.24, sub 4);
- undamped oscillations do not occur after the step change response;
- The initial delay time shall be as short as possible; if the initial response time is beyond 2 s, the PGFO has to offer a reasonable justification to the RSO;
- the time for full activation t_2 of the frequency response, no longer than 30 s;
- the insensitivity of active power frequency response at any relevant operating point does not exceed 10 mHz (point (d) of Article 15(2) and Netcode elektriciteit Article 3.24, sub 3).

FSM Simulations

Simulation procedure

The simulation shall be carried out by simulating frequency steps and ramps big enough to trigger the whole active power frequency response range, taking into account the droop settings and the deadband, as well as the capability to actually increase or decrease active power output from the respective operating point.

The FSM will be effective at frequencies between the LFSM thresholds 49.8 Hz and 50.2 Hz⁵:

- In case of overfrequency, the active power frequency response is limited by the Minimum Regulating Level,
- in case of underfrequency, the active power frequency response is limited by Maximum Capacity,
- the actual delivery of active power frequency response depends on the operating and ambient conditions of the Power-Generating Module when this response is triggered, in particular limitations on operation near maximum capacity at low frequencies according to paragraphs 4 and 5 of Article 13 and available primary energy sources.

After each frequency step or ramp the PGM should maintain the new operating point until the PGM active power output has stabilised.

For this simulation, the frequency response deadband setting shall be 0 mHz and the droop setting shall be 5%. A frequency step change of 200 mHz corresponds with 8% active power response. For larger frequency step changes the LFSM-O/U will be active.

Simulation of step response

- The simulation will be carried out for the same active power operating point as was applied in the corresponding test;

⁵ The FSM response is additional to the LFSM and will not be effective in the frequency range in which the LFSM-O/U will be active.

- The same sequences will be simulated as in the corresponding frequency step test and frequency ramp test;
- During each simulation:
 - Simulate until the active power output of the PGM has stabilized
 - Report the initial delay time t_1
 - Report the time for full activation time t_2 of the frequency response
 - Report the active power response.

Simulation evaluation criteria

The simulation shall be deemed successful if the following conditions are fulfilled:

- the activation time of full active power frequency response range as a result of a frequency step change is no longer than 30 s (required by point (d)(iii) of RfG Article 15(2) and Netcode elektriciteit Article 3.24, sub 4);
- undamped oscillations do not occur after the step change response;
- The initial delay time shall be as short as possible; if the initial response time is beyond 2 s, the PGFO has to offer a reasonable justification to the RSO;
- the time for full activation t_2 of the frequency response, no longer than 30 s;
- the insensitivity of active power frequency response at any relevant operating point does not exceed 10 mHz (point (d) of Article 15(2) and Netcode elektriciteit Article 3.24, sub 3);
- The simulation model of the Power Park Module is validated for the tested range against the compliance test for FSM response by expert judgement.

4.2.4 Frequency restoration

Applicable to:

SPGM	PPM	OPPM			Type C	Type D
------	-----	------	--	--	--------	--------

RfG article: 15(2)(e)

Netcode elektriciteit article: 3.24, sub 6

Test: RfG article 45(4) (SPGM), 48(5) (PPM, OPPM)

Simulation: none

Requirement to be verified

RfG Article 15(2): General requirements for type C Power-Generating Modules

- (e) with regard to frequency restoration control, the Power-Generating Module shall provide functionalities complying with specifications specified by the relevant TSO, aiming at restoring frequency to its nominal value or maintaining power exchange flows between control areas at their scheduled values;

Netcode elektriciteit Article 3.24, sub 6

The Power-Generating Module has functionalities, as described in RfG article 15(2) sub (e), that fulfil the requirements of GL SO articles 158 (FRR minimum technical requirements) and 159 (FRR prequalification process).

GL SO article 158(1) sub (d) and (f) states:

- (b) a FRR providing unit or FRR providing group shall activate FRR in accordance with the setpoint received from the reserve instructing TSO
- (d) a FRR providing unit or FRR providing group for automatic FRR shall have an automatic FRR activation delay not exceeding 30 seconds;
- (f) a FRR providing unit or FRR providing group for automatic FRR shall be capable of activating its complete automatic reserve capacity on FRR within the automatic FRR full activation time
- (g) a FRR providing unit or FRR providing group for manual FRR shall be capable of activating its complete manual reserve capacity on FRR within the manual FRR full activation time

Objective

To demonstrate the Power-Generating Module's technical capability to participate in frequency restoration control and to check the cooperation of FSM and frequency restoration control.

Frequency restoration Tests

Test procedure

The PGM controller will be triggered with a frequency deviation signal, in order to realise a new operating point according to the PGM frequency-power droop. For the frequency restoration test the PGM controller will be triggered with a different power setpoint and with the frequency deviation signal unchanged, causing the PGM to change its power output in order to contribute to recovery to the rated frequency (speed).

The test needs to be performed as follows:

- The droop setting is: 5%. While running in FSM, a frequency change of 200 mHz should cause a change of active power equal to 8% of the Maximum Capacity (SPGM) or 8% of P_{ref} (PPM and OPPM).
- The PGM must be connected with the grid
- The tests shall be carried out for an initial curtailed operating point between the PGM's Minimum Regulating Level and its Maximum Capacity from which it will be possible to test at least 20% active power increase. The operating point will be determined in consultation with the RSO. For SPGM the default operating point will be 70% of the Maximum Capacity. For a PPM the operating point shall be minimum 45% of the Maximum Capacity

- First, the PGM controller must be triggered with a -200mHz frequency deviation signal to obtain an active power output rise of 8% of its Maximum Capacity (SPGM) or 8% of P_{ref} (PPM) (from point (50;0) to point (49.8;8.0) in figure 4.11);
- When the PGM is running stable, the PGM controller must be triggered with a higher active power setpoint (10% of P_{ref}), while remaining the frequency deviation signal, in order to contribute to the frequency restoration (from point (49.8;8.0) to point (49.8;18.0) in figure 4.11);
- Next the frequency shall be increased to 50.0 Hz (from point (49.8;18) to point (50;10))
- The last step is to trigger the PGM controller with a lower active setpoint of -10% of P_{ref} . (from point (50.0;10.0) to point (50.0;0))
- At each test step hold for at least 15 minutes (SPGM); 2 minutes (PPM and OPPM);

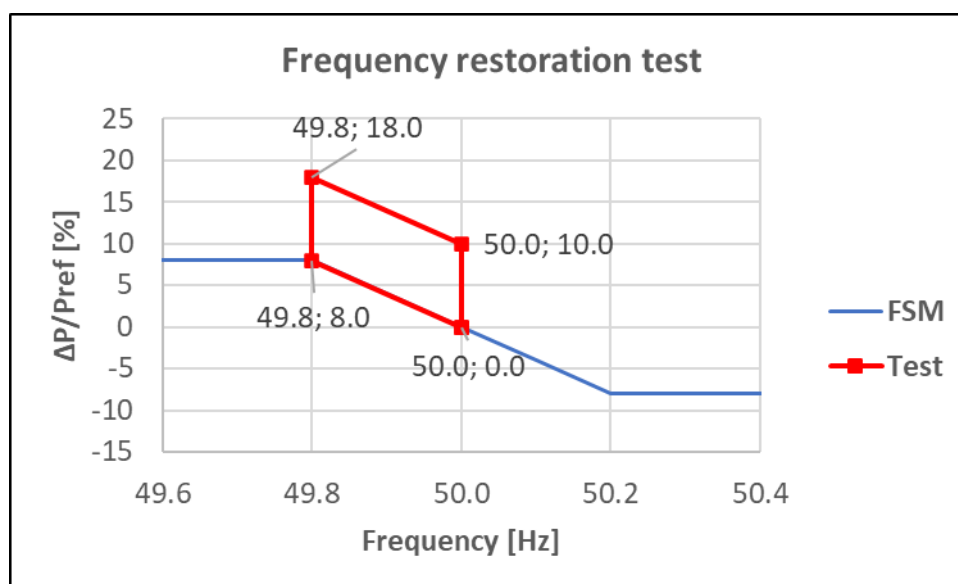

Figure 4.11 Frequency restoration test points corresponding to 5% droop

Documentation/measurements

The following signals (as function of time) should be recorded as a minimum:

- the grid frequency or turbine speed;
- the frequency change injection signal;
- the active power setpoint;
- the active power at the Connection Point.

Test evaluation criteria

The test shall be deemed successful if the results, for both dynamic and static parameters, comply with the requirements of point (e) of Article 15(2):

- The PGM is technically capable to participate in Frequency Restoration Reserve (FRR)
- The FRR activation delay shall not exceed 30 seconds.

4.2.5 Black start capability (if applicable)

Applicable to:

SPGM					Type C	Type D
------	--	--	--	--	--------	--------

RfG article: 15(5)(a)

Netcode elektriciteit article: 3.17(8)(a), 3.24, sub 8 and 9, 9.28

Test: RfG article 45(5) (SPGM)

Simulation: if required by TSO

Requirement to be verified

Article 15: General requirements for type C Power-Generating Modules

5.Type C Power-Generating Modules shall fulfil the following requirements relating to system restoration:

(a) with regard to black start capability:

- (i) black start capability is not mandatory without prejudice to the Member State's rights to introduce obligatory rules in order to ensure system security;
- (ii) Power-Generating Facility Owners shall, at the request of the relevant TSO, provide a quotation for providing black start capability. The relevant TSO may make such a request if it considers system security to be at risk due to a lack of black start capability in its control area;
- (iii) a Power-Generating Module with black start capability shall be capable of starting from shutdown without any external electrical energy supply within a time frame specified by the relevant system operator in coordination with the relevant TSO;
- (iv) a Power-Generating Module with black start capability shall be able to synchronise within the frequency limits laid down in point (a) of Article 13(1) and, where applicable, voltage limits specified by the relevant system operator or in Article 16(2);
- (v) a Power-Generating Module with black start capability shall be capable of automatically regulating dips in voltage caused by connection of demand;
- (vi) a Power-Generating Module with black start capability shall:
 - be capable of regulating load connections in block load,
 - be capable of operating in LFSM-O and LFSM-U, as specified in point (c) of [RfG article 15] paragraph 2 and [RfG] Article 13(2),
 - control frequency in case of overfrequency and underfrequency within the whole active power output range between minimum regulating level and maximum capacity as well as at houseload level,
 - be capable of parallel operation of a few Power-Generating Modules within one island, and
 - control voltage automatically during the system restoration phase;

The frequency limits laid down in Netcode elektriciteit Article 3.17(8)(b) are: 47.5 Hz – 51.0 Hz.

The voltage limits laid down in Netcode elektriciteit Article 3.17(8)(a) are:

- type C 0.90 pu – 1.10 pu;

The voltage limits laid down in RfG Article 16(2) for unlimited time are:

- type D 110 kV up to 300 kV: 0.90 pu – 1.118 pu;
- type D 300 kV to 400 kV: 0.90 pu – 1.05 pu.

According to Netcode elektriciteit article: 3.24, sub 8 and 9:

8. The PGM with black-start functionality is capable to start from a complete shutdown according to the specifications published by the RSO.
9. The PGM with black-start functionality is capable to synchronise according to the specifications published by the RSO.

According to Netcode elektriciteit Article: 9.28, sub 2:

The TSO acquires black-start possibilities in a size to be determined by him. He determines the preferred locations and he uses the product specifications as referred to in Article 4, second paragraph, part b, of the NC ER, as included in Appendix 5.

Objective

With regard to the black start capability test the following requirements shall apply:

- for a PGM with black start capability, this technical capability to start from shut down without any external electrical energy supply shall be demonstrated;
- to demonstrate that the PGM is able to energise a de-energised substation
- to demonstrate that the PGM is able to energise a de-energised network as indicated by the TSO
- to demonstrate that the PGM is able to run at low load during a significant time
- to demonstrate that the PGM is able to synchronise with and be paralleled with a network that is operating within the limits of RfG article 13(1) and RfG article 16(2) at an off-nominal frequency and voltage.

Black start capability Tests

The black-start test will be executed at least once per calendar year.

Test procedure

- All steps including all necessary switching actions are laid down in the detailed test protocol as part of the black start agreement;
- The PGM with black start capability must be at complete standstill during at least 4 hours, without any connection to the Connection Point or any other external electrical energy supply;
 - All the auxiliary gas turbines and/or auxiliary diesel engines in the facility in

- which that PGM with black start capability is situated, shall be shut down;
- The relevant PGM with black start capability shall be de-loaded and de-synchronised and all alternating current electrical supplies to its auxiliary system shall be disconnected;
- The emergency generator may start automatically;
- The auxiliary gas turbine(s) or auxiliary diesel engine(s) to the relevant PGM with black start capability shall be started, and shall re-energise the auxiliary system of the relevant PGM;
- Energise the step-up transformer according to the energising method that is described in the detailed test protocol;
- The relevant PGM will be capable to connect to a de-energised RSO bus bar and to maintain this section at a stable voltage of 100% U_n ;
- Energise the designated network section according to the energising method that is described in the detailed test protocol;
- The relevant PGM with black start capability shall be synchronised to the system;
- In accordance with the RSO the relevant PGM will be powered up to an agreed active power output.

Documentation/measurements

The following signals (as function of time) should be recorded as a minimum:

- speed, voltage, active and reactive power output of auxiliary gas turbine/diesel generators for Black Start function;
- terminal voltages of auxiliary MV and LV switchgear;
- auxiliary power output of emergency generators;
- turbine speed, -terminal voltage and active and reactive power output of the (gas)turbine that is started;
- active and reactive power output of the (gas)turbine that is started at the Connection Point;
- voltage and frequency at the Connection Point.

Test evaluation criteria

- The PGM with black start capability successfully:
 - energises the designated network section to be energised;
 - injects or absorbs the reactive power of the designated network section to be energised;
 - in island mode maintains the energised network section at a stable voltage of 100% U_n ;
 - synchronising and paralleling to the public network
 - outputs active power according to the black-start agreement;
 - powers up to the minimum regulating level with a mean increment as stated in the Black Start agreement;
 - increases the active power output to the agreed level.
- The test shall be deemed successful if the start-up time is kept within the time frame

set out in the black-start agreement and if the PGM runs stable.

Black start capability simulation

The TSO can request the PGFO to conduct a simulation study to demonstrate the capability to energise the TSO network.

4.2.6 Tripping to houseload

Applicable to:

SPGM					Type C	Type D
------	--	--	--	--	--------	--------

RfG article: 15(5)(c)

Netcode elektriciteit article: 3.20

Test: RfG article 45(6) (SPGM)

Simulation: none

Requirement to be verified

RfG Article 15: General requirements for type C Power-Generating Modules; also applicable to type D:

5. Type C Power-Generating Modules shall fulfil the following requirements relating to system restoration:

- (c) with regard to quick re-synchronisation capability:
 - (i) in case of disconnection of the Power-Generating Module from the network, the Power-Generating Module shall be capable of quick re-synchronisation in line with the protection strategy agreed between the relevant system operator in coordination with the relevant TSO and the Power-Generating Facility;
 - (ii) a Power-Generating Module with a minimum re-synchronisation time greater than 15 minutes after its disconnection from any external power supply must be designed to trip to houseload from any operating point in its P-Q-capability diagram. In this case, the identification of houseload operation must not be based solely on the system operator's switchgear position signals;
 - (iii) Power-Generating Modules shall be capable of continuing operation following tripping to houseload, irrespective of any auxiliary connection to the external network. The minimum operation time shall be specified by the relevant system operator in coordination with the relevant TSO, taking into consideration the specific characteristics of prime mover technology.

Netcode elektriciteit, article 3.20:

1. If the Power-Generating Module with a maximum capacity of more than 5 MW, connected to a medium or high-voltage grid, is disconnected from the grid by a short-circuit in the grid, the Power-Generating Module is capable of running stable operation parallel to the grid with all generators in operation, within 30 minutes after the voltage returns. This requirement only applies if the grid voltage returns within 60 minutes.
2. If the period of 30 minutes is not technically possible, the relevant producer must explain this to the TSO. It must also be mentioned to the TSO within which time the stable operation will be possible.

Objective

To prove that the SPGM is capable to successfully trip to houseload from any operating point in its P-Q-capability diagram and continues to run in stable operation.

Tripping to houseload Tests

Test procedure

- The tests will be executed for maximum capacity and nominal reactive power limited by the network constraints;
- The SPGM will be disconnected from the network by opening the main circuit breaker;
- The SPGM will successfully go into houseload mode and will run stable for 1 hr;
- 1 hr after disconnection, the SPGM will be synchronised and reconnected to the network;
- Within 30 minutes after reconnection the SPGM will be able to run stable at minimum regulating level;
- The SPGM will be able to run stable at minimum regulating level for 1 hr after the 30 minutes for reaching the minimum regulating level have passed.

Documentation/measurements

The following signals will be reported as time functions:

- At the Connection Point: power (P, Q), Voltage (V), Current (I);
- Synchronisation of units.

Test evaluation criteria

The test shall be deemed successful:

- If tripping to houseload is successful;
- If stable houseload operation has been demonstrated for the period of 1 hr;
- If re-synchronisation to the network and stable running at minimum regulating level has been performed successfully.

4.2.7 Frequency range and Voltage range

Applicable to:

SPGM	PPM	OPPM	Type A	Type B	Type C	Type D
------	-----	------	--------	--------	--------	--------

RfG article: 13(1), 16(2), 25(1)

Netcode elektriciteit article: 3.13, sub 1, article 3.15, sub 9 to 11, article 3.28, sub 1, article 3.33, sub 1

Test: Required by RSO; not according to RfG

Simulation: none

Requirement to be verified

The frequency related requirements are applicable to PGM's of all types A, B, C and D.

The voltage related criteria are applicable to PGM's of type D only.

Article 13: General requirements for type A Power-Generating Modules

1. Type A power-generating modules shall fulfil the following requirements relating to frequency stability:

(a) With regard to frequency ranges:

- (i) a power-generating module shall be capable of remaining connected to the network and operate within the frequency ranges and time periods specified in Table 2;

RfG Table 2: Minimum time periods for which a power-generating module has to be capable of operating on different frequencies, deviating from a nominal value, without disconnecting from the network.

Frequency range	Time period for operation
47.5 Hz – 48.5 Hz	To be specified by each TSO, but not less than 30 minutes
48.5 Hz – 49.0 Hz	To be specified by each TSO, but not less than the period for 47.5 Hz-48.5 Hz
49.0 Hz – 51.0 Hz	Unlimited
51.0 Hz – 51.5 Hz	30 minutes

Netcode elektriciteit article 3.13, sub 1:

The power-generating module is capable of operating on different frequencies, deviating from a nominal value, without disconnecting from the network:

- a. for frequencies between 47.5 Hz and 48.5 Hz: during 30 minutes;
- b. for frequencies between 48.5 Hz and 49.0 Hz: during 30 minutes;
- c. for frequencies between 49.0 Hz and 51.0 Hz: during unlimited time;
- d. for frequencies between 51.0 Hz and 51.5 Hz: during 30 minutes.

Netcode elektriciteit article 3.15, sub 9:

The power-generating module, connected to a medium voltage network or a high voltage network below 110 kV, is, in addition to Netcode elektriciteit article 3.13, first and seventh paragraph, capable of operating on different voltages, deviating from a nominal value, without disconnecting from the network:

- a. during 20 minutes at a voltage at the Connection Point between 0.85 pu and 0.90 pu, whereby, without prejudice to the sixth paragraph sub b of article 3.15, the active power may be reduced to 80% of the maximum capacity;
- b. in accordance with the periods referred to in Netcode elektriciteit article 3.13, first paragraph:
 - a. at a voltage at the Connection Point within the voltage band between 0.9 pu and 1.1 pu and within a frequency range from 50.0 Hz to 51.5 Hz;
 - b. at a voltage at the Connection Point within the voltage band which varies linearly from 0.9 pu and 1.01 pu at 47.5 Hz to 0.9 and 1.1 pu at 50 Hz;

Netcode elektriciteit article 3.15, sub 10:

The power-generating module, connected to a medium voltage network or a high voltage network below 110 kV, is capable, pursuant to Netcode elektriciteit article 3.15, ninth paragraph, and pursuant to Netcode elektriciteit article 3.13, first paragraph, to remain connected and in operation within the time periods, frequency ranges and voltage bands shown in the diagram below.

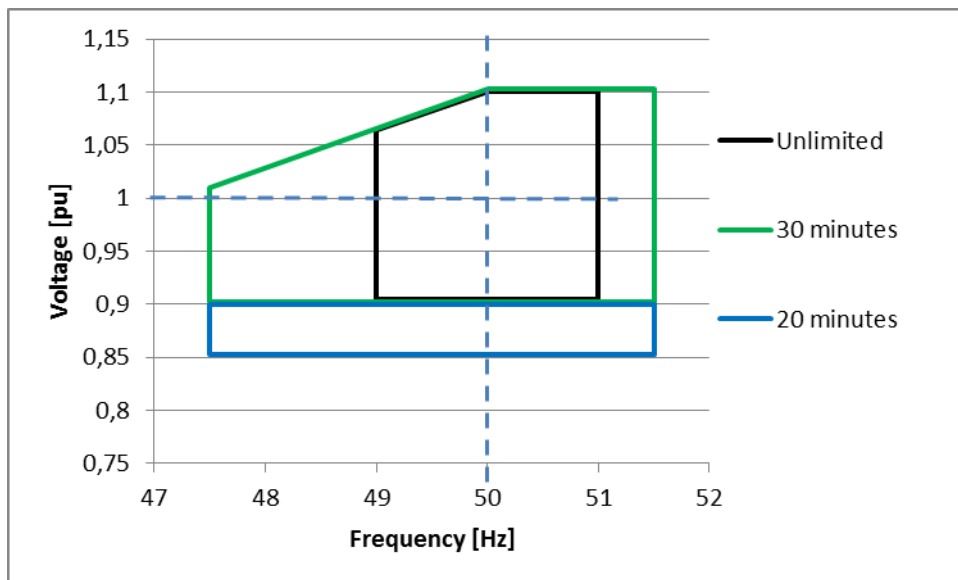

Figure 4.12 Voltage against frequency profile for PGM with nominal voltage < 110 kV

Article 16: General requirements for type D Power-Generating Modules

2. Type D Power-Generating Modules shall fulfil the following requirements relating to voltage stability:

(a) with regard to voltage ranges:

- (i) without prejudice to point (a) of [RfG] Article 14(3) and point (a) of [RfG] Article 16(3), a Power-Generating Module shall be capable of staying connected to the network and operating within the ranges of the network voltage at the Connection Point, expressed by the voltage at the Connection Point related to the reference 1 pu voltage, and for the time periods specified in [RfG] Tables 6.1 and 6.2;

RfG Table 6.1: voltage base for pu values is from 110 kV to 300 kV (for type D)

Voltage range	Time period for operation
0.85 pu – 0.90 pu	60 minutes
0.90 pu – 1.118 pu	Unlimited
1.118 pu – 1.15 pu	To be specified by each TSO, but not less than 20 minutes and not more than 60 minutes

RfG Table 6.2: voltage base for pu values is from 300 kV to 400 kV (for type D)

Voltage range	Time period for operation
0.85 pu – 0.90 pu	60 minutes
0.90 pu – 1.05 pu	Unlimited
1.05 pu – 1.10 pu	To be specified by each TSO, but not less than 20 minutes and not more than 60 minutes

Netcode elektriciteit article 3.28, sub 1:

The time period for the voltage range from 1.118 pu to 1.15 pu in networks with nominal voltage between 110 kV and 300 kV and for the voltage range from 1.05 pu to 1.10 pu in networks with nominal voltage between 300 kV (inclusive) and 400 kV is 20 minutes.

Article 25: Voltage stability requirements applicable to AC-connected offshore power park modules

1. Without prejudice to point (a) of [RfG] Article 14(3) and point (a) of [RfG] Article 16(3), an AC-connected offshore power park module shall be capable of staying connected to the network and operating within the ranges of the network voltage at the connection point, expressed by the voltage at the connection point related to reference 1 pu voltage, and for the time periods specified in [RfG] Table 10.

RfG Table 10: voltage base for pu values is below 300 kV

Voltage range	Time period for operation
0.85 pu – 0.90 pu	60 minutes
0.90 pu – 1.118 pu	Unlimited
1.118 pu – 1.15 pu	To be specified by each TSO, but not less than 20 minutes and not more than 60 minutes

Netcode elektriciteit article 3.33, sub 1:

The OPPM, connected to a network with nominal voltage below 300 kV is capable to stay connected to the network and to stay in operation during the next time periods:

- a. unlimited for the voltage range between 0.9 pu and 1.118 pu;
- b. 60 minutes for the voltage range between 0.85 pu and 0.90 pu;
- c. 60 minutes for the voltage range between 1.118 pu and 1.15 pu.

Objective

To prove that the PGM is capable to stay connected to the network and operate within the ranges of the network frequency and voltage at the Connection Point.

Frequency range and Voltage range tests

Test procedure for Synchronous Power Generating Module

The test procedure demonstrates the capability of the SPGM to operate within the required voltage ranges.

The voltage on the auxiliary system will be controlled using the on-load tap-changer on the step-up transformer or on the auxiliary transformer:

- The minimum voltage is: 85%;

The duration should be at least as required in Netcode elektriciteit, Article 3.15, sub 9 and 10 for SPGM types A, B and C and in RfG tables 6.1 and 6.2 for SPGM type D:

- The minimum voltage is 85%:
 - For SPGM types A to C: during at least 20 minutes; the active power may be reduced to 80% of the maximum capacity;
 - For SPGM type D: during at least 60 minutes;
- The maximum voltage is 110%:
 - For SPGM with voltage base below 110 kV: during at least 60 minutes;
- The maximum voltage is 115% (voltage base until from 110 kV to 300 kV) or 110% (voltage base from 300 kV):
 - For SPGM: during at least 20 minutes.

The duration may be shorter if the step-up transformer or auxiliary transformer is equipped with an automatically controlled on-load tap changer.

If the minimum or maximum voltage cannot be reached with the tap-changer, the extreme tap changer positions will be used.

Test procedure for (O)PPM

The test procedure demonstrates the capability of the (O)PPM to operate within the required voltage ranges and frequency ranges. The aim of this test is to demonstrate the capability of the (O)PPM to long term operate on the voltage and frequency limits at full load (active power) and simultaneously at maximum reactive power. The test should cover both main power generating components (e.g. wind turbine nacelle and inverter) and control system inclusive auxiliary system.

Particularly at low voltage and maximum capacity and maximum reactive power the currents will be high, which will cause temperature rise in main components in generator, inverters and transformers. Correction of the temperature-rise values shall be made for ambient air temperatures.

In case of a full-inverter type Generating Unit, the grid-connected inverter (including rectifier part) and step-up transformer (if applicable) shall be included in this test. With respect to the available test capabilities, it will be accepted if inverter and (step-up) transformer are tested separately.

The frequency range test shall be executed as type test on a Generating Unit. The most critical parts of one unit shall be tested to verify the capability to run within the required frequency ranges and voltage ranges. The frequency range will be tested as type test on a Generating Unit at maximum capacity and maximum reactive power:

- The minimum frequency is 47.5 Hz during at least 30 minutes
- The maximum frequency is 51.5 Hz during at least 30 minutes

The voltage range capability of (O)PPM's connected to medium voltage or higher may be tested as type test on a Generating Unit at maximum capacity and maximum reactive power. The duration should be at least as required in Netcode elektriciteit, Article 3.15, sub 9 and 10 for PPM types A, B and C and in RfG tables 6.1 and 6.2 for PPM type D and in RfG table 10 for OPPM:

- The minimum voltage is 85%:
 - For PPM types A to C: during at least 20 minutes; the active power may be reduced to 80% of the maximum capacity;
 - For PPM type D: during at least 60 minutes; it is permitted to reduce the active power, as much as is technically necessary to limit the maximum current, in favour of providing reactive power;
 - For OPPM: during at least 60 minutes;
- The maximum voltage is 110%:
 - For PPM and OPPM with voltage base below 110 kV (except 66 kV): during at least 60 minutes;
- The maximum voltage is 72,5 kV:
 - For PPM and OPPM connected to a network with nominal voltage of 66 kV: during at least 60 minutes;

- The maximum voltage is 115% (voltage base from 110 kV to 300 kV) or 110% (voltage base from 300 kV):
 - For PPM type D: during at least 20 minutes;
 - For OPPM: during at least 60 minutes.

Both NC RfG and Netcode elektriciteit do not specify the voltage range for PGM's connected to low voltage networks. A requirement will be implemented in the Netcode elektriciteit in future. The requirement will be similar to the requirement in the current standard NEN-EN 50549-1: When generating power, the generating plant shall be capable of operating continuously when the voltage at the point of connection stays within the range of 85% U_n to 110% U_n . In case of voltages below U_n , it is allowed to reduce the apparent power to maintain the current limits of the generating plant. The reduction shall be as small as technically feasible.

The voltage range of PGM's connected to low voltage networks will be tested as type test on a Generating Unit at maximum capacity:

- The minimum voltage is below 86% during at least 10 minutes;
- The maximum voltage is above 109% during at least 10 minutes.

Documentation/measurements

The following signals will be reported:

- Time of start and end of test;
- PGM voltage and frequency as time function;
- PGM active and reactive power output as time functions
- Ambient and PGM temperatures as time functions in relation to PGM error messages.

Test evaluation criteria

The test is deemed successful if:

- The PGM stays connected to the network within the specified frequency ranges and voltage ranges during and after the test;
- In case of a full-inverter type Generating Unit, the DC-link between wind-turbine generator and grid shall be within rated voltage during the applied voltage envelope;
- The currents of the solid-state components shall operate within nominal values during the applied voltage and frequency envelope;
- The measured temperatures, corrected for the ambient temperature, remain within the specified ranges.

4.2.8 Reactive power capability

Applicable to:

SPGM	PPM	OPPM		Type B	Type C	Type D
------	-----	------	--	--------	--------	--------

RfG article: 18(2)(b/c), 21(3)(b/c), 25(5)

Netcode elektriciteit article: 2.27 (all connections), 3.15 (type A), 3.18, sub 1-4 (SPGM Type B), 3.19, sub 1-9 (PPM type B), 3.25, sub 1-3 (SPGM type C), 3.26, sub 1-2 (PPM type C), 3.29, sub 1-4 (SPGM type D), 3.30, sub 1-4 (PPM type D), 3.33, sub 2-4 (OPPM), 3.34, sub 2-4 (OPPM)

Test: RfG article 45(7) (SPGM), 48(6) (PPM), 50 (OPPM)

Simulation: RfG article 52(5) (SPGM), 55(6) (PPM), 57 (OPPM)

Requirement to be verified

RfG Article 18: Requirements for synchronous Power-Generating Modules type C and D < 300kV

2. Type C synchronous Power-Generating Modules shall fulfil the following additional requirements in relation to voltage stability:

(b) with regard to reactive power capability at maximum capacity:

- (i) the relevant system operator in coordination with the relevant TSO shall specify the reactive power provision capability requirements in the context of varying voltage. For that purpose the relevant system operator shall specify a U-Q/P_{max}-profile within the boundaries of which the synchronous Power-Generating Module shall be capable of providing reactive power at its maximum capacity. The specified U-Q/P_{max} profile may take any shape, having regard to the potential costs of delivering the capability to provide reactive power production at high voltages and reactive power consumption at low voltages;
- (ii) the U-Q/P_{max}-profile shall be specified by the relevant system operator in coordination with the relevant TSO, in conformity with the following principles:
 - the U-Q/P_{max}-profile shall not exceed the U-Q/P_{max}-profile envelope, represented by the inner envelope in [RfG] Figure 7,
 - the dimensions of the U-Q/P_{max}-profile envelope (Q/P_{max} range and voltage range) shall be within the range specified for each synchronous area in [RfG] Table 8, and
 - the position of the U-Q/P_{max}-profile envelope shall be within the limits of the fixed outer envelope in [RfG] Figure 7;

Maximum range of Q/P_{max}: 0.95

Maximum range of steady- state voltage level in pu: 0.225

- (iii) the reactive power provision capability requirement applies at the Connection Point. For profile shapes other than rectangular, the voltage range represents the highest and lowest values. The full reactive power range is therefore not expected to be available across the range of steady-state voltages;

- (iv) the synchronous Power-Generating Module shall be capable of moving to any operating point within its U-Q/ P_{max} profile in appropriate timescales to target values requested by the relevant system operator;
- (c) with regard to reactive power capability below maximum capacity, when operating at an active power output below the maximum capacity ($P < P_{max}$), the synchronous Power-Generating Modules shall be capable of operating at every possible operating point in the P-Q-capability diagram of the alternator of that synchronous Power-Generating Module, at least down to minimum stable operating level. Even at reduced active power output, reactive power supply at the Connection Point shall correspond fully to the P-Q-capability diagram of the alternator of that synchronous Power-Generating Module, taking the auxiliary supply power and the active and reactive power losses of the step-up transformer, if applicable, into account.

Article 21 Requirements for Power Park Modules type C and D < 300kV

3. Type C Power Park Modules shall fulfil the following additional requirements in relation to voltage stability:

- (b) with regard to reactive power capability at maximum capacity:
 - (i) the relevant system operator in coordination with the relevant TSO shall specify the reactive power provision capability requirements in the context of varying voltage. To that end, it shall specify a U-Q/ P_{max} -profile that may take any shape within the boundaries of which the Power Park Module shall be capable of providing reactive power at its maximum capacity;
 - (ii) the U-Q/ P_{max} -profile shall be specified by each relevant system operator in coordination with the relevant TSO in conformity with the following principles:
 - the U-Q/ P_{max} -profile shall not exceed the U-Q/ P_{max} -profile envelope, represented by the inner envelope in [RfG] Figure 8,
 - the dimensions of the U-Q/ P_{max} -profile envelope (Q/ P_{max} range and voltage range) shall be within the values specified for each synchronous area in [RfG] Table 9,
 - the position of the U-Q/ P_{max} -profile envelope shall be within the limits of the fixed outer envelope set out in [RfG] Figure 8, and
 - the specified U-Q/ P_{max} profile may take any shape, having regard to the potential costs of delivering the capability to provide reactive power production at high voltages and reactive power consumption at low voltages;

Maximum range of Q/ P_{max} : 0.75

Maximum range of steady- state voltage level in pu: 0.225

- (iii) the reactive power provision capability requirement applies at the Connection Point. For profile shapes other than rectangular, the voltage range represents the highest and lowest values. The full reactive power range is therefore not expected to be available across the range of steady-state voltages;

- (c) with regard to reactive power capability below maximum capacity:
- (i) the relevant system operator in coordination with the relevant TSO shall specify the reactive power provision capability requirements and shall specify a P-Q/ P_{max} -profile that may take any shape within the boundaries of which the Power Park Module shall be capable of providing reactive power below maximum capacity;
 - (iii) when operating at an active power output below maximum capacity ($P < P_{max}$), the Power Park Module shall be capable of providing reactive power at any operating point inside its P-Q/ P_{max} -profile, if all units of that Power Park Module which generate power are technically available that is to say they are not out of service due to maintenance or failure, otherwise there may be less reactive power capability, taking into consideration the technical availabilities;
 - (iv) the Power Park Module shall be capable of moving to any operating point within its P-Q/ P_{max} profile in appropriate timescales to target values requested by the relevant system operator;

Article 25 Voltage stability requirements applicable to AC-connected offshore power park modules

5. The reactive power capability at maximum capacity specified in point (b) of [RfG] Article 21(3) shall apply to AC- connected offshore power park modules, except for [RfG] Table 9. Instead, the requirements of [RfG] Table 11 shall apply.

Maximum range of Q/P_{max} : 0.75

Maximum range of steady- state voltage level in pu: 0.225

Netcode elektriciteit article 2.27 (all connections):

If the connected party has not made any further contractual agreements with the RSO, the power factor in the connection point varies between 0.85 (inductive) and 1.0, unless there are short-term deviations and periods with very low loads.

Netcode elektriciteit article 3.15 (PGM Type A):

Notwithstanding the provisions of Article 2.27, the power factor of a PGM, connected to a medium-voltage or high-voltage network having a voltage level less than 110 kV, at the transfer point will be between 0.98 capacitive and 0.98 inductive.

SPGM

Netcode elektriciteit article 3.18, sub 1, 2, 3 and 4 (SPGM Type B)

1. The SPGM is capable of supplying a maximum amount of reactive power at varying voltage, which is characterized by a ratio of reactive power to maximum capacity, as referred to in Article 17, second paragraph, part a, of Regulation (EU) 2016/631 (NC RfG):

- a. Equal to 0.33 at a voltage of 0.9 pu to 1.05 pu; and
- b. which is determined by the linear gradient between 0.33 and 0.0, respectively, at a voltage between 1.05 pu and 1.1 pu;

2. The power park module is capable of absorbing a maximum amount of reactive power at varying voltage, which is characterized by a ratio of reactive power to maximum capacity, as referred to in Article 17, second paragraph, part a, of Regulation (EU) 2016/631 (NC RfG):
 - a. Equal to 0.33 at a voltage of 0.95 pu to 1.1 pu; and
 - b. which is determined by the linear gradient between 0.0 and 0.33, respectively, at a voltage between 0.9 pu and 0.95 pu;
3. In addition to the first paragraph, it is permitted to reduce the active power, as much as technically necessary for the limitation by the maximum current, in favour of supplying reactive power within the part of the U - Q/P_{\max} -profile that is limited by the linear gradient between 0.2 and 0.33 respectively at a voltage between 0.90 pu and 0.95 pu and the profile in accordance with the first paragraph;
4. Pursuant to article 3.18, paragraphs 1 to 3, the power park module is capable of supplying or absorbing reactive power within and including the limits of the red marked U - Q/P_{\max} profile in the diagram below:

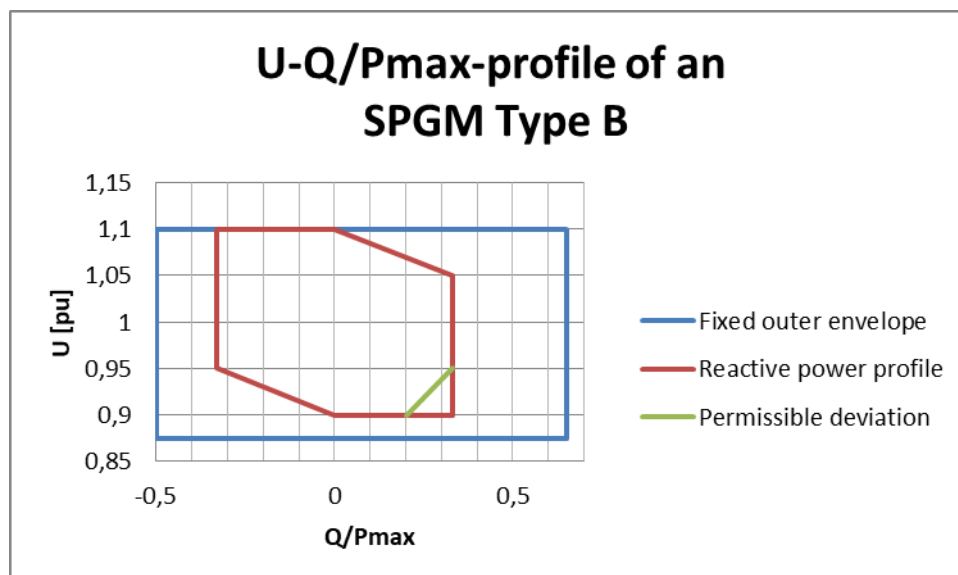

Netcode elektriciteit article 3.25, sub 1, 2 and 3 (SPGM Type C and type D < 300 kV)

1. The SPGM is capable of supplying a maximum amount of reactive power at varying voltage, which is characterized by a ratio of reactive power to maximum capacity, as referred to in Article 18, second paragraph, part b, of Regulation (EU) 2016/631 (NC RfG):
 - a. Equal to 0.55 at a voltage of 0.9 pu to 1.05 pu; and
 - b. which is determined by the linear gradient between 0.55 and 0.3, respectively, at a voltage between 1.05 pu and 1.1 pu;
2. The power park module is capable of absorbing a maximum amount of reactive power at varying voltage, which is characterized by a ratio of reactive power to maximum capacity, as referred to in Article 18, second paragraph, part b, of Regulation (EU) 2016/631 (NC RfG):
 - a. Equal to 0.4 at a voltage of 1.0 pu to 1.1 pu; and

- b. which is determined by the linear gradient between 0.1 and 0.4, respectively, at a voltage between 0.9 pu and 1.0 pu;
3. Pursuant to article 3.25, paragraphs 1 and 2, the power park module is capable of supplying or absorbing reactive power within and including the limits of the red marked U- Q/P_{max} profile in the diagram below:

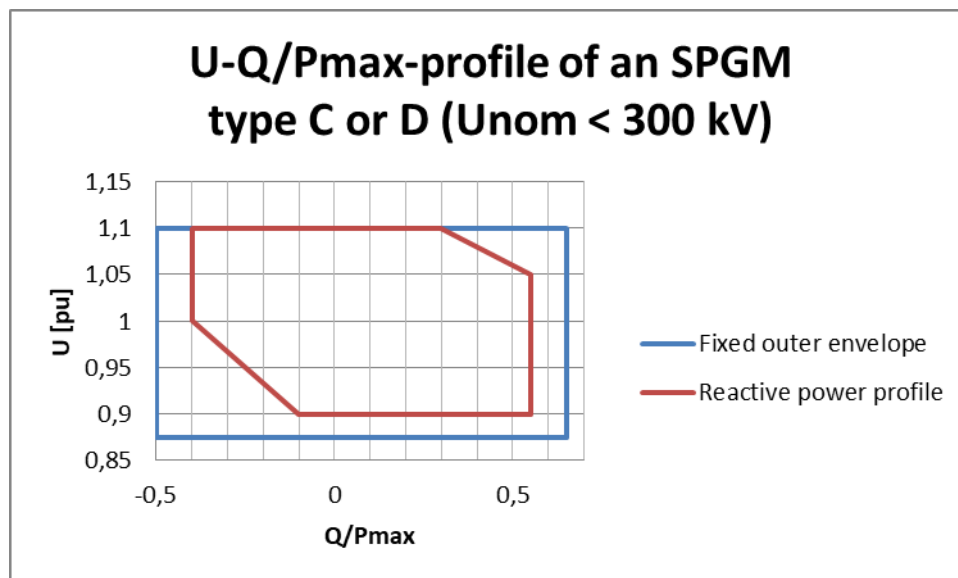

Netcode elektriciteit article 3.29, sub 2, 3 and 4 (SPGM Type D ≥ 300 kV)

2. The SPGM is capable of supplying a maximum amount of reactive power at varying voltage, which is characterized by a ratio of reactive power to maximum capacity, as referred to in Article 18, second paragraph, part b, of Regulation (EU) 2016/631 (NC RfG):
- a. Equal to 0.3 at a voltage of 1.05 pu
 - b. Equal to 0.55 at a voltage of 0.9 pu to 1.0 pu; and
 - c. which is determined by the linear gradient between 0.55 and 0.3, respectively, at a voltage between 1.0 pu and 1.05 pu;
3. The power park module is capable of absorbing a maximum amount of reactive power at varying voltage, which is characterized by a ratio of reactive power to maximum capacity, as referred to in Article 18, second paragraph, part b, of Regulation (EU) 2016/631 (NC RfG):
- a. Equal to 0.1 at a voltage of 0.9 pu
 - b. Equal to 0.4 at a voltage of 1.0 pu to 1.05 pu; and
 - c. which is determined by the linear gradient between 0.1 and 0.4, respectively, at a voltage between 0.9 pu and 1.0 pu;
4. Pursuant to article 3.29, paragraphs 2 and 3, the power park module is capable of supplying or absorbing reactive power within and including the limits of the red marked U- Q/P_{max} profile in the diagram below:

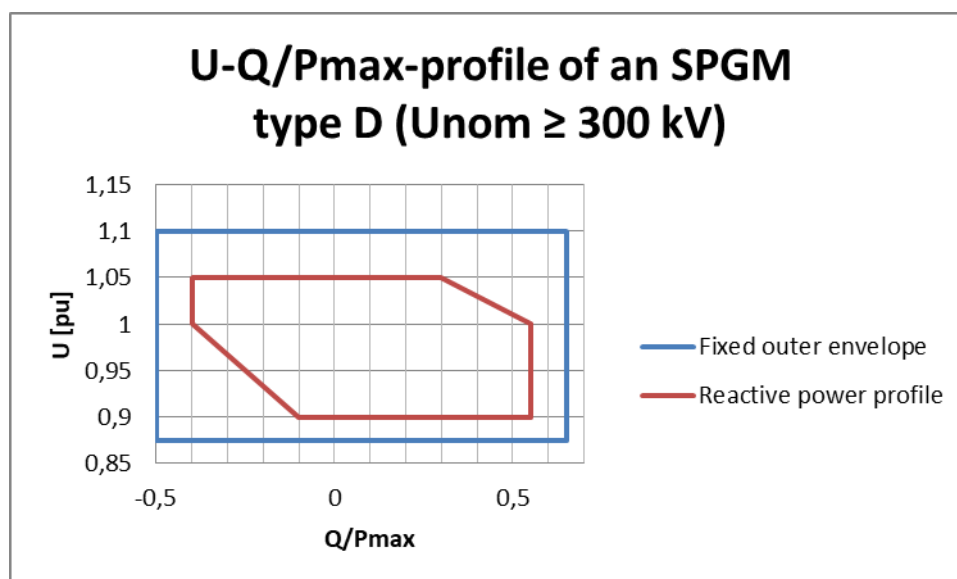

PPM

Netcode elektriciteit article 3.19, sub 1, 2, 3 and 4 (PPM Type B, C and D < 300kV)

1. The power park module is capable at its maximum capacity of supplying a maximum amount of reactive power at varying voltage, which is characterized by a ratio of reactive power to maximum capacity, as referred to in Article 20, second paragraph, part a, of Regulation (EU) 2016/631 (NC RfG):

- a. Equal to 0.33 at a voltage of 0.9 pu to 1.05 pu;
- b. which is determined by the linear gradient between 0.33 and 0.0, respectively, at a voltage between 1.05 pu and 1.1 pu;

2. The power park module is capable of absorbing at its maximum capacity a maximum amount of reactive power at varying voltage, which is characterized by a ratio of reactive power to maximum capacity, as referred to in Article 20, second paragraph, part a, of Regulation (EU) 2016/631 (NC RfG):

- a. Equal to 0.33 at a voltage of 0.95 pu to 1.1 pu;
- b. which is determined by the linear gradient between 0.0 and 0.33, respectively, at a voltage between 0.9 pu and 0.95 pu;

3. In addition to the first paragraph, it is permitted to reduce the active power, as much as technically necessary for the limitation by the maximum current, in favour of supplying reactive power within the part of the U-Q/P_{max}-profile that is limited by the linear gradient between 0.2 and 0.33 respectively at a voltage between 0.90 pu and 0.95 pu and the profile in accordance with the first paragraph;

4. Pursuant to article 3.19, paragraphs 1 to 3, the power park module is capable of supplying or absorbing reactive power within and including the limits of the red marked U-Q/P_{max} profile in the diagram below:

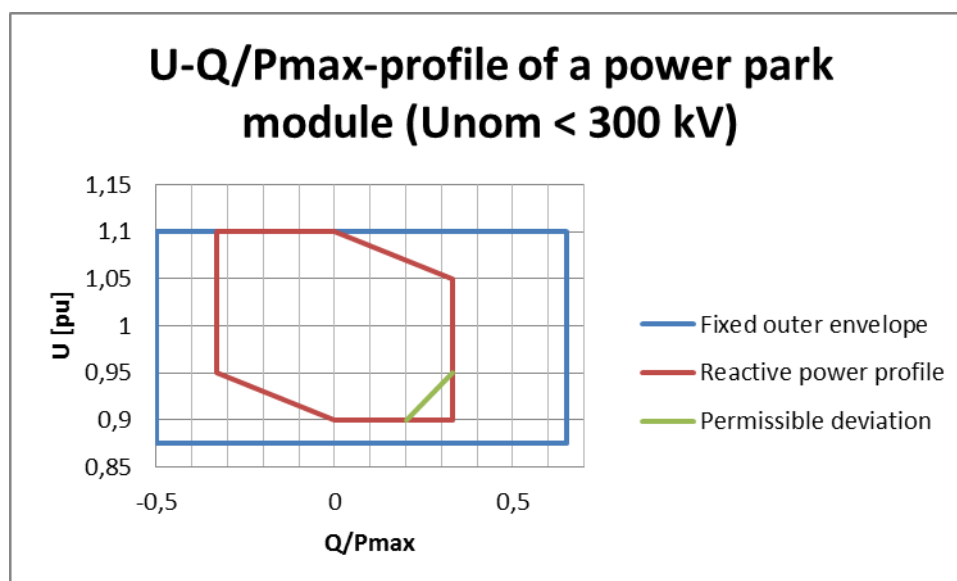

Figure 4.13 U-Q/P_{max} profile of a power park module Type B and Type C and Type D (U_{nom} < 300 kV)

Netcode elektriciteit article 3.19, sub 5, 6, 7, 8, 9 (PPM Type B, C and D)

5. The power park module is able of supplying a maximum reactive power that is characterized by a ratio of reactive power to maximum capacity as referred to in Article 20 (2) (a) of Regulation (EU) 2016 / 631 (NC RfG):

- a. equal to 0.33 at an active power of 0.2 pu to 1 pu;
- b. which is determined by the linear gradient between 0.0 and 0.33 respectively at an active power of 0.0 pu to 0.2 pu;

6. The power park module is able of absorbing a maximum reactive power that is characterized by a ratio of reactive power to maximum capacity as referred to in Article 20 (2) (a) of Regulation (EU) 2016 / 631 (NC RfG):

- a. equal to 0.33 at an active power of 0.2 pu to 1 pu;
- b. which is determined by the linear gradient between 0.0 and 0.33 respectively at an active power of 0.0 pu to 0.2 pu;

7. In addition to the fifth and sixth paragraphs, at an active power between 0.93 pu and 1.0 pu, it is permitted to reduce the active power as much as technically necessary regarding the maximum current limitation to a value described by the linear gradient of Q/P_{max} between 0.0 and 0.33 at active power of 1.0 pu and 0.93 pu, respectively, in favour of providing reactive power;

8. In addition to the fifth and sixth paragraphs, it is permitted (if the exchanged apparent power is less than 10% of the maximum apparent power) to supply or absorb the requested reactive power in accordance with the technical possibilities and with a deviation of maximum 10% of the maximum apparent power.

9. Pursuant to article 3.19, paragraphs 5 to 8, the power park module is capable of supplying or absorbing reactive power within and including the limits of the red marked P-Q/P_{max} profile in the diagram below:

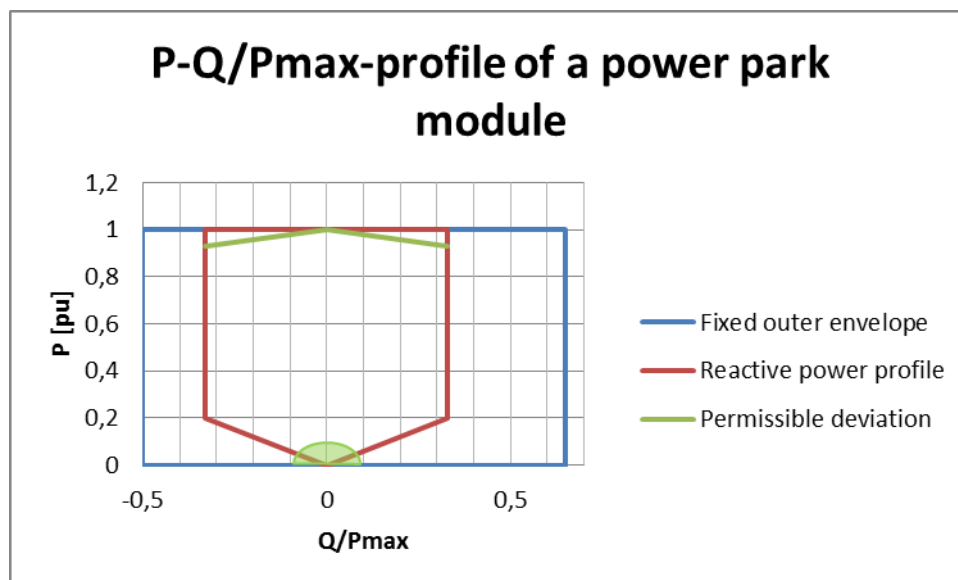

Figure 4.14 P-Q/P_{max} profile of a power park module Type B and Type C

Netcode elektriciteit article 3.26, sub 1 and 2 (PPM Type C)

1. The U-Q/P_{max}-profile, as referred to in Article 21, third paragraph, part b, subpart i, of Regulation (EU) 2016/631 (NC RfG), within which a power park module must be able to supply and absorb reactive power, is equal to the U-Q/P_{max}-profile as referred to in Article 3.19, first to fourth paragraph [PPM Type B];

2. The P-Q/P_{max}-profile, as referred to in Article 21, third paragraph, part c, subpart i, of Regulation (EU) 2016/631 (NC RfG), within which a power park module must be able to supply and absorb reactive power, is equal to the P-Q/P_{max}-profile as referred to in Article 3.19, fifth to ninth paragraph [PPM Type B];

Netcode elektriciteit article 3.27, sub 4 (PPM Type D)

4. Power Generating Units of type D, comply to the requirements in paragraph 3.6 [PPM Type C], except article 3.24, sub 7.

Netcode elektriciteit article 3.30, sub 1 and 2 (PPM Type D ≥ 300kV)

1. The power park module connected to a high-voltage network with a voltage level equal to or greater than 300 kV is capable of supplying a maximum amount of reactive power at varying voltage, which is characterized by a ratio of reactive power to maximum capacity, as referred to in Article 21, third paragraph, part b, subpart i of Regulation (EU) 2016/631 (NC RfG)):

- a. equal to 0.33 at a voltage of 0.9 pu to 1 pu;

- b. which is determined by the linear gradient between 0.33 and 0.0, respectively, at a voltage between 1.0 pu and 1.05 pu;
2. The power park module connected to a high-voltage network with a voltage level equal to or greater than 300 kV is capable of absorbing a maximum amount of reactive power at varying voltage, which is characterized by a ratio of reactive power to maximum capacity, as referred to in Article 21, third paragraph. (b), subpart i of Regulation (EU) 2016/631 (NC RfG)):
- a. Equal to 0.33 at a voltage of 0.95 pu to 1.05 pu;
 - b. which is determined by the linear gradient between 0.33 and 0.0, respectively, at a voltage between 0.95 pu and 0.9 pu;
3. In addition to the first paragraph, it is permitted to reduce the active power, as much as technically necessary for the limitation by the maximum current, in favour of providing reactive power within the part of the U - Q/P_{max} -profile that is limited by the linear gradient between 0.2 and 0.33 respectively at a voltage between 0.90 pu and 0.95 pu and the profile in accordance with the first paragraph;
4. The power park module connected to a high-voltage network with a voltage level equal to or greater than 300 kV is, pursuant to the first through third paragraph, capable of supplying or absorbing reactive power within and including the limits of the red marked U - Q/P_{max} -profile in the diagram below;

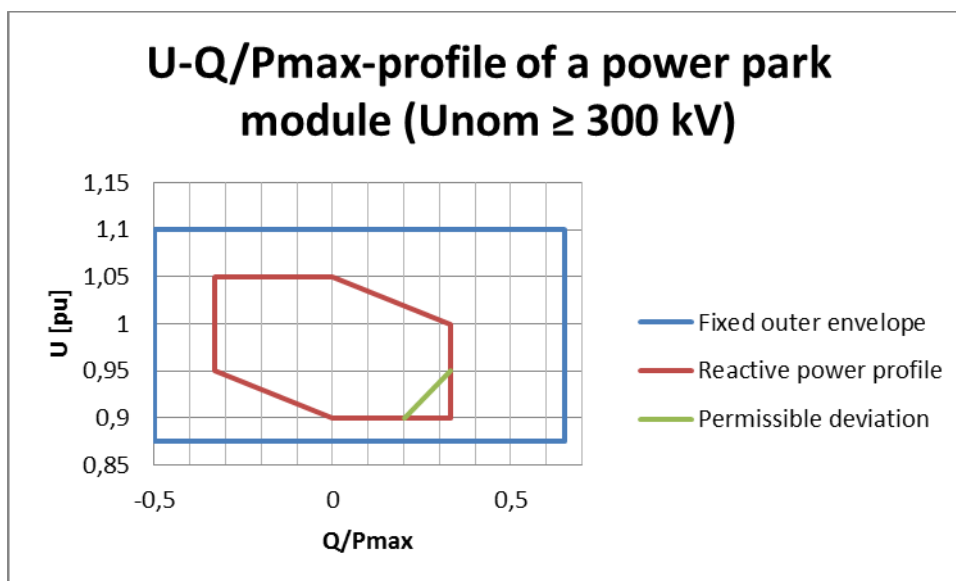

Figure 4.15 U - Q/P_{max} profile of a power park module Type D (U_{nom} ≥ 300 kV)

5. If the power park module is connected to a high-voltage network with a voltage level of 110 kV or higher via a transformer with a load-adjustable (on-line) step changer, the deviation referred to in the third paragraph and in Article 3.19, third and third seventh paragraph, permitted only during the control action of the transformer step changer;

OPPM

Netcode elektriciteit article 3.33, sub 4 (OPPM where the voltage base for pu values is below 300 kV):

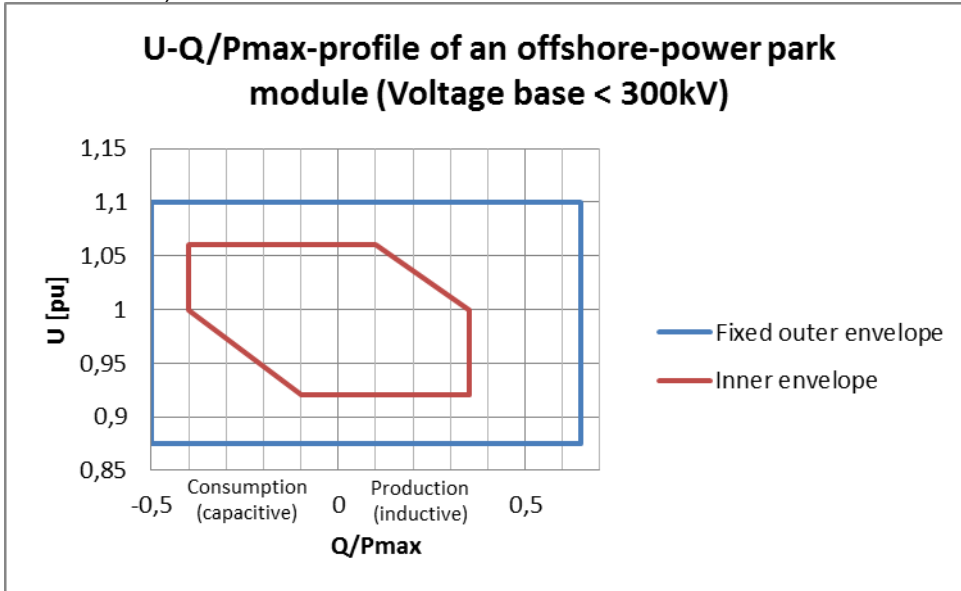

Figure 4.16 U-Q/P_{max}-profile for OPPM where the voltage base for pu values is below 300 kV

Netcode elektriciteit article 3.34, sub 4 (OPPM):

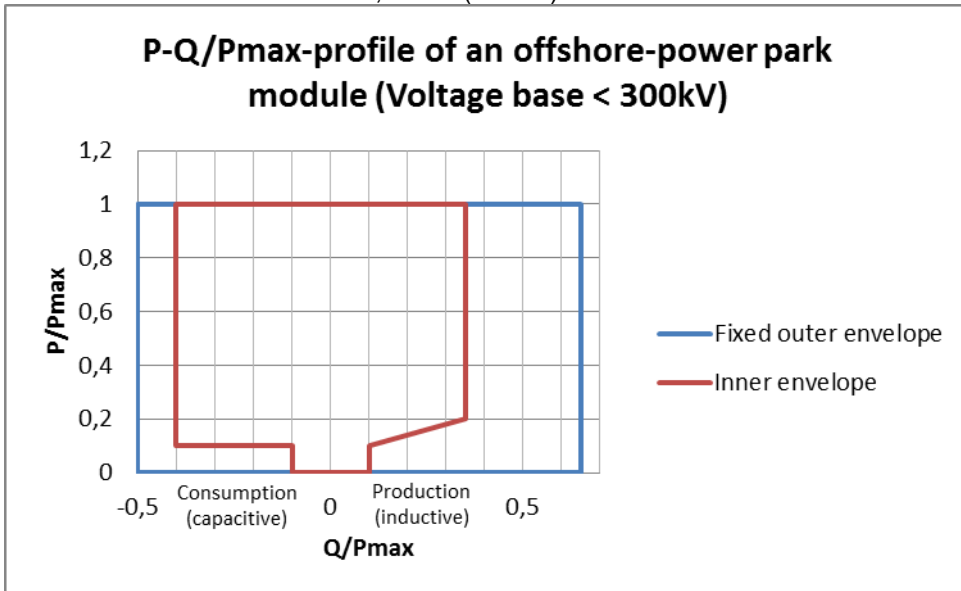

Figure 4.17 P-Q/P_{max}-profile for OPPM

Objective

To demonstrate the Power-Generating Module's technical capability to provide leading and lagging reactive power capability in accordance with points (b) and (c) of Article 18(2), points (b) and (c) of Article 21(3) and Article 25(5).

- Lagging Reactive Power is the export of Reactive Power from the Power-Generating Module to the Total System and has a positive sign (production by the PGM).
- Leading Reactive Power is the import of Reactive Power from the Total System to the Power-Generating Module and has a negative sign (consumption by the PGM).

Reactive power capability Tests (applicable to PPM type B)

In the case of a PPM type B of which each Generating Unit is only controlled by an individual Generating Unit controller and not by a PGM (park) controller, if certificates for this requirement are available for all generating units and other dynamically active components in the PPM, these may be used together with load flow based network calculations to demonstrate the PPM reactive power capability at the connection point. In that case an on-site test will not be required by the RSO.

If no certificates are available, or a PGM (park) controller is used, the test shall be performed according to the reactive power capability test for PGM type C and D, however with a reduced duration of 10 minutes per test.

Reactive power capability Tests (applicable to PGM type C and D)

Test procedure

For this test the Power-Generating Module has to operate at a number of operating points at the extremes of its operating range. The set of operating points is derived from the profiles as listed in the Netcode elektriciteit, articles 3.18, 3.19, 3.25, 3.29, 3.30, 3.33 and 3.34.

During the tests the voltage at the Connection Point is:

- For SPGM and PPM with nominal voltage below 300 kV in the range: 0.9 pu – 1.118 pu
- For SPGM and PPM with nominal voltage 300 kV or higher in the range: 0.9 pu – 1.05 pu
- For OPPM in the range: 0.9 pu – 1.118 pu

The tests will be executed for several active power operating points:

- For SPGM: Minimum stable operating level, Maximum Capacity and a medium active power point (an Active Power operating point between minimum and maximum)
- For PPM and OPPM: low, medium and high active power output, expressed as percentage of the Maximum Capacity.

In the tests the maximum leading reactive power is a negative value and the maximum lagging reactive power is a positive value for Q/P_{\max} :

Reactive Power	Maximum leading (capacitive)	Maximum lagging (inductive)
	Q/P_{\max}	Q/P_{\max}
SPGM type B	-0.33	0.33
SPGM type C or D	-0.4	0.55
PPM	-0.33	0.33
OPPM	-0.4	0.35

The test procedure for SPGM contains 6 points. In each operating point the SPGM shall run stable during the relevant time in the table.

Table SPGM test durations

Point	Active power output	Reactive power output	Duration
1	Minimum stable operating level	Maximum leading	60 min
2	Minimum stable operating level	Maximum lagging	60 min
3	Medium	Maximum leading	60 min
4	Medium	Maximum lagging	60 min
5	Maximum capacity	Maximum leading	60 min
6	Maximum capacity	Maximum lagging	60 min

The test procedure for PPM and OPPM contains 6 points.. In each operating point the PPM shall run stable during the relevant time in the table.

Table PPM and OPPM test durations

Point	Active power output	Reactive power output	Duration
1	10% – 20%	Maximum leading	60 min
2	10% – 20%	Maximum lagging	60 min
3	30% – 50%	Maximum leading	30 min
4	30% – 50%	Maximum lagging	30 min
5	More than 60%	Maximum leading	30 min
6	More than 60%	Maximum lagging	30 min

Documentation/measurements

The following signals (as function of time) should be recorded as a minimum:

- At the Connection Point: P, Q, V, I.
- Tap changer positions of transformers, if applicable
- At reactive power compensation equipment if applicable: Switching on/off position, Q, V, I

Test evaluation criteria

For SPGM type C or D, the test shall be deemed successful if the following conditions are fulfilled:

- the SPGM operates at maximum reactive power for at least one hour, both leading and lagging, at minimum stable operating level, maximum capacity, and an active power operating point between those maximum and minimum levels;
- the SPGM's capability to change to any reactive power target value within the agreed or decided reactive power range shall be demonstrated.

For PPM and OPPM type C or D, the test shall be deemed successful if the following criteria are fulfilled:

- the (O)PPM operates for a duration no shorter than the requested duration at maximum reactive power, both leading and lagging, in each parameter specified in RfG Article 48 paragraph 6(b);
- the (O)PPM's capability to change to any reactive power target value within the agreed or decided reactive power range is demonstrated;
- no protection action takes place within the operation limits specified by the reactive power capacity diagram.

Reactive power capability Simulations

Simulation procedure

The simulation model of the PGM will be validated against the compliance tests for reactive power capability and compliance with the requirements will be demonstrated. In order to do this, in the simulation the voltage at the Connection Point and the operating points shall be the same as in the tests.

The simulations will be executed for several active power operating points:

- For SPGM: Minimum stable operating level, Maximum Capacity and a medium active power point (an Active Power operating point between minimum and maximum)
- For PPM and OPPM: low, medium and high active power output, expressed as percentage of the Maximum Capacity.

In the simulations the maximum leading reactive power is a negative value and the maximum lagging reactive power is a positive value for Q/P_{\max} :

Reactive Power	Maximum leading (capacitive)	Maximum lagging (inductive)
	Q/P_{\max}	Q/P_{\max}
SPGM type B	-0.33	0.33
SPGM type C or D	-0.4	0.55
PPM	-0.33	0.33
OPPM	-0.4	0.35

The simulation procedure for SPGM contains 6 points. The transition from one point to the other is part of the simulation. In each operating point the SPGM shall run stable.

Table SPGM simulations

Point	Active power output	Reactive power output
1	Minimum regulating level	Maximum leading
2	Minimum regulating level	Maximum lagging
3	Medium	Maximum leading
4	Medium	Maximum lagging
5	Maximum capacity	Maximum leading
6	Maximum capacity	Maximum lagging

The simulation procedure for PPM and OPPM contains 6 points.. In each operating point the PPM shall run stable during the relevant time in the table.

Table PPM and OPPM simulations

Point	Active power output	Reactive power output
1	10% – 20%	Maximum leading
2	10% – 20%	Maximum lagging
3	30% – 50%	Maximum leading
4	30% – 50%	Maximum lagging
5	More than 60%	Maximum leading
6	More than 60%	Maximum lagging

Additional simulations for SPGM

To assess the extreme points of the $U-Q/P_{\max}$ - and $P-Q/P_{\max}$ -profiles and the behaviour of the generating units at their terminals, the following simulations shall be executed for cases with different voltage, active and reactive power.

For a SPGM Type B

Case	Voltage	Active power output	Reactive power output
1	1.0 pu	100%	Maximum leading
2	1.0 pu	100%	Maximum lagging
3	1.0 pu	Minimum regulating level	Maximum leading
4	1.0 pu	Minimum regulating level	Maximum lagging
5	1.0 pu	0% (offline)	No requirement
6	1.1 pu	100%	Maximum leading
7	1.1 pu	100%	0%
8	1.05 pu	100%	Maximum lagging
9	0.95 pu	100%	Maximum lagging
10	0.95 pu	100%	Maximum leading
11	0.9 pu	100% ²⁾	Between 20% P _{max} and Maximum lagging
12	0.9 pu	100% ¹⁾	0%
13	0.85 pu	100% ²⁾	No requirement

For a SPGM Type C and Type D < 300 kV

Case	Voltage	Active power output	Reactive power output
1	1.0 pu	100%	Maximum leading
2	1.0 pu	100%	Maximum lagging
3	1.0 pu	Minimum regulating level	Maximum leading
4	1.0 pu	Minimum regulating level	Maximum lagging
5	1.0 pu	0% (offline)	No requirement
6	1.1 pu	100%	Maximum leading
7	1.1 pu	100%	30% P _{max} lagging
8	1.05 pu	100%	Maximum lagging
9	0.9 pu	100%	Maximum lagging
10	0.9 pu	100%	10% P _{max} leading
11	0.85 pu	100% ²⁾	No requirement

For a SPGM Type D ≥ 300 kV:

Case	Voltage	Active power output	Reactive power output
1	1.0 pu	100%	Maximum leading
2	1.0 pu	100%	Maximum lagging
3	1.0 pu	Minimum regulating level	Maximum leading
4	1.0 pu	Minimum regulating level	Maximum lagging
5	1.0 pu	0% (offline)	No requirement
6	1.05 pu	100%	Maximum leading
7	1.05 pu	100%	30% Pmax lagging
8	0.9 pu	100%	Maximum lagging
9	0.9 pu	100%	10% Pmax leading
10	0.85 pu	100% ²⁾	No requirement

- 1) According to Netcode elektriciteit article 3.18, sub 3, at low voltage between 0.9 pu and 0.95 pu and high active and reactive power output, it is permitted to reduce the active power, as much as technically necessary for the limitation by the maximum current in favour of supplying reactive power
- 2) According to Netcode elektriciteit article 3.15, sub 9a, at low voltage between 0.85 pu and 0.9 pu, with a duration of max. 20 minutes it is permitted to reduce the active power to 80% of P_{max} .

Additional simulations for PPM and OPPM:

To assess the extreme points of the U-Q/ P_{max} - and P-Q/ P_{max} -profiles and the behaviour of the generating units at their terminals, the following simulations shall be executed for cases with different voltage, active and reactive power.

For a PPM Type B, C and Type D < 300 kV

Case	Voltage	Active power output	Reactive power output
1	1.0 pu	100% ¹⁾	Maximum leading
2	1.0 pu	100% ¹⁾	Maximum lagging
3	1.0 pu	20%	Maximum leading
4	1.0 pu	20%	Maximum lagging
5	1.0 pu	0%	Between -10% and 10% of P_{max}
6	1.1 pu	100% ¹⁾	Maximum leading
7	1.1 pu	100%	0%
8	1.05 pu	100% ¹⁾	Maximum lagging
9	0.95 pu	100% ²⁾	Maximum lagging
10	0.95 pu	100% ²⁾	Maximum leading
11	0.9 pu	100% ²⁾	Between 20% of P_{max} and Maximum lagging
12	0.9 pu	100% ²⁾	0%
13	0.85 pu	100% ³⁾	No requirement

For a PPM Type D \geq 300 kV:

Case	Voltage	Active power output	Reactive power output
1	1.0 pu	100% ¹⁾	Maximum leading
2	1.0 pu	100% ¹⁾	Maximum lagging
3	1.0 pu	20%	Maximum leading
4	1.0 pu	20%	Maximum lagging
5	1.0 pu	0%	Between -10% and 10% of P_{max}
6	1.05 pu	100% ¹⁾	Maximum leading
7	1.05 pu	100%	0%
8	0.95 pu	100% ²⁾	Maximum lagging
9	0.9 pu	100% ²⁾	Between 20% of P_{max} and Maximum lagging
10	0.9 pu	100% ²⁾	0%
11	0.95 pu	100% ²⁾	Maximum leading
12	0.85 pu	100% ³⁾	No requirement

For an OPPM:

Case	Voltage	Active power output	Reactive power output
1	1.0 pu	100% ¹⁾	Maximum leading
2	1.0 pu	100% ¹⁾	Maximum lagging
3	1.0 pu	10%	Maximum leading
4	1.0 pu	20%	Maximum lagging
5	1.0 pu	0%	10% of P_{max} leading
6	1.0 pu	0%	10% of P_{max} lagging
7	1.06 pu	100% ¹⁾	Maximum leading
8	1.06 pu	100%	10% of P_{max} lagging
9	0.92 pu	100% ²⁾	Maximum lagging
10	0.92 pu	100% ²⁾	10% of P_{max} leading
11	0.85 pu	100% ³⁾	No requirement

- 1) According to Netcode elektriciteit article 3.19, sub 7, at high active and reactive power output, it is permitted to reduce the active power as much as technically necessary regarding the maximum current limitation by the linear gradient of Q/P_{max} between 0.0 and 0.33 at active power of 1.0 pu and 0.93 pu, respectively, in favour of providing reactive power;
- 2) According to Netcode elektriciteit article 3.19, sub 3, at low voltage between 0.9 pu and 0.95 pu and high active and reactive power output, it is permitted to reduce the active power, as much as technically necessary for the limitation by the maximum current in favour of supplying reactive power
- 3) According to Netcode elektriciteit article 3.15, sub 9a, at low voltage between 0.85 pu and 0.9 pu, with a duration of max. 20 minutes it is permitted to reduce the active power to 80% of P_{max} .

Documentation/calculated parameters

The following signals (as function of time) should be recorded as a minimum:

- At the point of common coupling: P, Q, V, I;
- In case of a PPM or OPPM: at the generating unit terminals: P, Q, V, I;
- Tap changer positions of transformers, if applicable;
- At reactive power compensation equipment if applicable: Switching on/off position, Q, V, I.

Simulation evaluation criteria

For SPGM, the simulation shall be deemed successful :

- If the simulation model of the Power-Generating Module is validated against the compliance tests for reactive power capability;
- If the SPGM operates at maximum reactive power, both leading and lagging at

minimum stable operating level, maximum capacity, and an active power operating point between those maximum and minimum levels;

- If the SPGM's capability to change to any reactive power target value within the agreed or decided reactive power range without violating protection settings is demonstrated.

For PPM and OPPM, the simulation shall be deemed successful :

- If the simulation model of the Power-Generating Module is validated against the compliance tests for reactive power capability;
- If the (O)PPM operates at maximum reactive power, both leading and lagging at operating level between 10% and 20% of the maximum capacity, operating level between 30% and 50% of the maximum capacity, operating level in excess of 60% of the maximum capacity;
- If the Power-Generating Module's capability to change to any reactive power target value within the agreed or decided reactive power range without violating protection settings is demonstrated.

4.2.9 Active power controllability

Applicable to:

	PPM	OPPM			Type C	Type D
--	-----	------	--	--	--------	--------

RfG article: 15(2)(a)

Netcode elektriciteit article: 3.24, sub 1

Test: RfG article 48(2) (PPM, OPPM)

Simulation: none

Requirement to be verified

RfG Article 15: General requirements for type C Power-Generating Modules

2. Type C Power-Generating Modules shall fulfil the following requirements relating to frequency stability:

- (a) with regard to active power controllability and control range, the Power-Generating Module control system shall be capable of adjusting an active power setpoint in line with instructions given to the Power-Generating Facility Owner by the relevant system operator or the relevant TSO.

The relevant system operator or the relevant TSO shall establish the period within which the adjusted active power setpoint must be reached. The relevant TSO shall specify a tolerance (subject to the availability of the prime mover resource) applying to the new setpoint and the time within which it must be reached;

Netcode elektriciteit, Article 3.24

1. The Power-Generating Module is capable of receiving a setpoint of the active power and to follow it according to the instructions of the relevant TSO. The following conditions apply:
 - a. The control range is between the minimum regulating level and the actual maximum capacity, unless otherwise agreed between the TSO and the connected party
 - b. The time period within which the adjusted setpoint for the active power must be achieved is laid down in the Connection Agreement (ATO)
 - c. The tolerance for the new reference value is +/-2% of the maximum capacity.

Objective

To demonstrate the Power Park Module's technical capability to operate at a load level below the setpoint set by the relevant system operator or the relevant TSO. The PPM shall not produce a power output higher than the Active Power Setpoint. A modified Active Power Setpoint shall be implemented within a time period and with a defined accuracy, both recorded in the Connection Agreement (ATO).

Active power controllability Tests

Test procedure

The PPM must be in operation and connected with the grid. The value of the power factor is not relevant for this test and a value of 1 at the Connection Point is suggested. A signal is injected into the active power setpoint controller input of the PPM.

The starting point for the test will be:

- an active power output of more than 60% of the maximum capacity;
- PPM in reactive power control mode, $Q_{ref} = 0$ Mvar.

The active power setpoint is then adjusted to command a lower active power output in steps of 10% of the during the test available active power until the lowest possible active power output. After each step the PPM is allowed the agreed time (as specified in the ATO) to set to the new setpoint. Then the active power output will be measured as a one-minute average.

Documentation/measurements

- P, Q, V shall be measured as function of the time at the Connection Point as momentary values or as one-minute average;
- Active power setpoint
- Applied settings of PPM and GU controllers;

Test evaluation criteria

The test shall be deemed successful if the following conditions are fulfilled:

- The load level of the power park module is kept below the setpoint;
- The setpoint is implemented according to the requirements laid down in RfG Article 15(2)(a) and Netcode elektriciteit Article 3.24, sub 1;
- Reaction time of activation and the settling time are within the time periods recorded in the Connection Agreement (ATO);
- The accuracy of the regulation complies with the value specified in point (a) of Article 15(2) and Netcode elektriciteit Article 3.24, sub 1: the tolerance for the new reference value is +/-2% of the maximum capacity.

4.2.10 Voltage control mode (sub-mode 1 and sub-mode 2)

Applicable to:

SPGM	PPM	OPPM		Type B	Type C	Type D
------	-----	------	--	--------	--------	--------

RfG article: 21(3)(d)

Netcode elektriciteit article: 3.26, sub 4, 6, 9

Test: RfG article 48(7) (PPM, OPPM)

Simulation: none

With regard to the tests referred to in RfG article 48, paragraphs 7, 8 and 9, the relevant system operator may select only one of the three control options (voltage/reactive power/power factor) for testing.

Requirement to be verified

RfG Article 17: Requirements for type B synchronous power-generating modules

2. Type B synchronous power-generating modules shall fulfil the following additional requirements relating to voltage stability:

- (a) with regard to reactive power capability, the relevant system operator shall have the right to specify the capability of a synchronous power-generating module to provide reactive power;
- (b) with regard to the voltage control system, a synchronous power-generating module shall be equipped with a permanent automatic excitation control system that can provide constant alternator terminal voltage at a selectable setpoint without instability over the entire operating range of the synchronous power-generating module.

RfG Article 19: Requirements for type D synchronous power-generating modules

2. Type D synchronous power-generating modules shall fulfil the following additional requirements in relation to voltage stability:

- (a) the parameters and settings of the components of the voltage control system shall be agreed between the power-generating facility owner and the relevant system operator, in coordination with the relevant TSO;

- (b) the agreement referred to in subparagraph (a) shall cover the specifications and performance of an automatic voltage regulator ('AVR') with regard to steady-state voltage and transient voltage control and the specifications and performance of the excitation control system.

RfG Article 21: Requirements for type C Power Park Modules

3. Type C Power Park Modules shall fulfil the following additional requirements in relation to voltage stability:

(d) with regard to reactive power control modes:

- (i) the Power Park Module shall be capable of providing reactive power automatically by either voltage control mode, reactive power control mode or power factor control mode;
- (ii) for the purposes of voltage control mode, the Power Park Module shall be capable of contributing to voltage control at the Connection Point by provision of reactive power exchange with the network with a setpoint voltage covering 0,95 to 1,05 pu in steps no greater than 0,01 pu, with a slope having a range of at least 2 to 7 % in steps no greater than 0,5 %. The reactive power output shall be zero when the grid voltage value at the Connection Point equals the voltage setpoint;
- (iii) the setpoint may be operated with or without a deadband selectable in a range from zero to ± 5 % of reference 1 pu network voltage in steps no greater than 0,5 %;
- (iv) following a step change in voltage, the Power Park Module shall be capable of achieving 90 % of the change in reactive power output within a time t1 to be specified by the relevant system operator in the range of 1 to 5 seconds, and must settle at the value specified by the slope within a time t2 to be specified by the relevant system operator in the range of 5 to 60 seconds, with a steady-state reactive tolerance no greater than 5 % of the maximum reactive power. The relevant system operator shall specify the time specifications;
- (vii) the relevant system operator, in coordination with the relevant TSO and with the Power Park Module owner, shall specify which of the above three reactive power control mode options and associated setpoints is to apply, and what further equipment is needed to make the adjustment of the relevant setpoint operable remotely;

RfG Article 2(57): 'slope' means the ratio of the change in voltage, based on reference 1 pu voltage, to a change in reactive power infeed from zero to maximum reactive power, based on maximum reactive power.

Netcode elektriciteit, Article 3.26 (Type C), paragraphs 4, 6 and 9

- 4. For the PPM, the times t1 (for a change of 90% of the reactive power) and t2 (for the stabilization of the reactive power), as referred to in RfG Article 21(3)(d) subsection (iv), are agreed between the RSO and the connected party, in consultation with the TSO. The values are recorded in the Connection Agreement (ATO).

6. The Connection Agreement (ATO) stipulates whether automatic reactive power is provided by the PPM, as referred to in RfG Article 21(3)(d), subsection (vii), by means of:
 - a. voltage control mode sub-mode 1, where the exchanged reactive power is in an agreed bandwidth, which is also included in the Connection Agreement (ATO),
 - b. voltage control mode sub-mode 2, without requirement regarding the exchanged reactive power,
 - c. reactive power control mode or
 - d. power factor control mode;
9. The priority of the contribution of the active power or the reactive power during interruptions where fault-ride-through capacity is required is location-specific. This option will be agreed upon between the RSO and the connected party, in consultation with the TSO, and will be included in the Connection Agreement (ATO).

Reactive Power Control of PGMs Requirements:

- Voltage control mode sub-mode 1:

Function: voltage control (U-control), characterized by voltage droop, setpoint voltage and control speed, with additional functionality to periodically check and if necessary adjust locally the setpoint voltage to adjust the reactive power exchange at the Connection Point to the reference steady state reactive power exchange:

 - In case the reactive power exchange at the Connection Point has exceeded the predefined Dynamic Threshold (solid green lines in the figure 4.18), but has not exceeded the predefined Disturbance Threshold, the setpoint voltage must be adjusted by the PGM to re-establish the agreed steady state reactive power exchange at the Connection Point within 15 minutes (this is a slow control function over the voltage control);
 - In case the reactive power exchange at the Connection Point or the voltage deviation at the Connection Point exceeds the predefined Disturbance Threshold (solid red lines in the figure 4.18), the reactive power support of the PGM must be maintained for at least 15 minutes (this is a standard voltage control functionality).

The graph below illustrates the (in time varying) reactive power exchange, crossing the dynamic upper limit, resulting in a voltage setpoint adjustment; later the reactive power setpoint is changed from 0 Mvar to approximately 15 Mvar; the reactive power exchange is crossing the dynamic lower limit, resulting in a voltage setpoint adjustment; later, as result of an external event, the reactive power exchange crosses the dynamic and the disturbance limits showing that the reactive power support of the PGM is maintained.

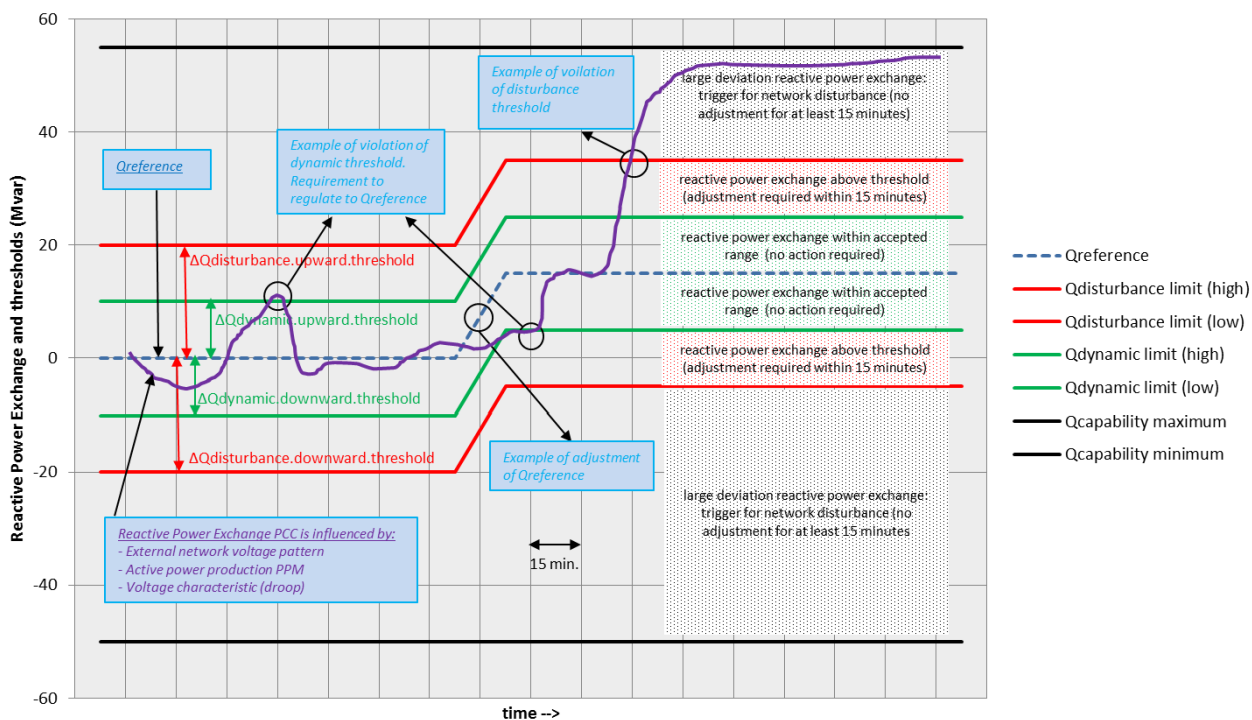

Figure 4.18 Example of Reactive Power Exchange of a Generator or (O)PPM at the PCC and Reactive Power thresholds in Voltage control mode sub-mode 1

- Voltage control mode sub-mode 2:
 Function: Voltage control (U-control), characterized by voltage droop, setpoint voltage and control speed.
 In sub-mode 2 the additional functionality to periodically check and if necessary adjust locally the setpoint voltage to adjust the reactive power exchange at the Connection Point to the reference steady state reactive power exchange is disabled.
 In case the voltage deviation at the Connection Point exceeds the predefined threshold, the reactive power support of the (O)PPM must be maintained for at least 15 minutes.

Objective

With regard to SPGM the voltage control mode shall be tested only if Voltage control mode sub-mode 1 has been agreed.

With regard to (O)PPM the following requirements shall apply:

- (a) the Power Park Module's capability to operate in voltage control mode referred to in the conditions set out in points (ii) to (iv) of RfG Article 21(3)(d) shall be demonstrated;
- (b) The voltage control mode test shall verify the following parameters:
 - (i) the implemented slope and deadband according to Article 21(3)(d)(iii);
 - (ii) the accuracy of the control;
 - (iii) the insensitivity of the control; and

- (iv) the time of reactive power activation;

Voltage control mode Tests

In case of an SPGM the voltage control mode shall be tested only if Voltage control mode sub-mode 1 has been agreed. In case of a (O)PPM either Voltage control mode sub-mode 1 or Voltage control mode sub-mode 2 shall be tested, depended on the choice with regard to RfG article 48, paragraph 10.

In case of a (O)PPM, before 20% of the (O)PPM has commissioned, the voltage control test must be completed.

Test procedure

Starting points:

- In case of a (O)PPM: the test should be scheduled at a time when there is sufficient MW resource forecasted in order to generate at least 20% of Maximum Capacity of the (O)PPM units in service;
- The test will be executed during normal operation; this means the PGM is in steady state operation with a power factor at the Connection Point as determined with the RSO (default value for the reference steady state reactive power exchange is 0 Mvar);
- The setpoint of reactive power control mode may be adjusted remotely or locally in the park-controller in case no remote control is available;
- The deadband will be set to zero;
- The slope (voltage droop) will be set to 2%;
- Q_{max} is the lowest value of the absolute maximum inductive (injected) and absolute maximum capacitive (absorbed) reactive power;
- The tests shall be executed by step-changing the "measured voltage signal" input of the voltage controller in both directions in full range until one of the following restriction applies:
 - The minimum or maximum voltage is reached (Q_{ref} setpoint);
 - The maximum absorbed or injected reactive power Q_{max} is reached according to the U-Q/ P_{max} profile;
 - One of the operational limits of the network of the RSO is reached; this restriction needs to be determined in advance and real time by the RSO; usually a real-time voltage range of 95%-105% of rated voltage applies.

Procedure for Voltage control mode sub-mode 1:

- Set Q_{ref} to 0
- Test for dynamic limit and disturbance limit:
 - Stepwise decrease "measured voltage" signal of the voltage controller by 0.1% and wait 1 minute after each step

- Repeat decreasing "measured voltage" signal of the voltage controller until the exchanged reactive power exceeds the Q upper dynamic limit
- Wait until the setpoint voltage is adjusted automatically and subsequently wait at least 1 minute
- Stepwise increase "measured voltage" signal of the voltage controller by 0.1% and wait 1 minute after each step
- Repeat increasing "measured voltage" signal of the voltage controller until the exchanged reactive power exceeds the Q lower dynamic limit
- Wait until the setpoint voltage is adjusted automatically and subsequently wait at least 1 minute
- Ramp down the "measured voltage" signal of the voltage controller with gradient 0.01% per second
- Ramp down until the exchanged reactive power exceeds the Q upper disturbance limit
- Hold at least 15 minutes
- Ramp up the "measured voltage" signal of the voltage controller with gradient 0.01% per second
- Ramp up until the exchanged reactive power exceeds the Q lower disturbance limit
- Hold at least 15 minutes
- Ramp down the "measured voltage" signal of the voltage controller with gradient 0.01% per second
- Ramp down until the exchanged reactive power equals Q_{ref}
- Increase Q_{ref} by 20%
 - Wait at least 1 minute
 - Repeat the Test for dynamic limit and disturbance limit
- Set Q_{ref} to 0
 - Wait at least 1 minute
- Decrease Q_{ref} by 20%
 - Wait at least 1 minute
 - Repeat the Test for dynamic limit and disturbance limit

Procedure for Voltage control mode sub-mode 2:

- Set Q_{ref} to 0
- Test for droop with measured voltage signal:
 - Stepwise decrease "measured voltage" signal of the voltage controller by 0.1% and wait 1 minute after each step
 - Repeat decreasing "measured voltage" signal of the voltage controller until the exchanged reactive power reaches its maximum production according to the U-Q/ P_{max} profile or the operational limit of the network
 - Stepwise increase "measured voltage" signal of the voltage controller by 0.1% and wait 1 minute after each step
 - Repeat increasing "measured voltage" signal of the voltage controller until

the exchanged reactive power reaches its maximum consumption according to the $U-Q/P_{\max}$ profile or the operational limit of the network

Documentation/measurements

- Prior to the start of the tests and any changes to the following, if any values change during the tests:
 - All relevant transformer tap positions (if applicable);
 - Number of Power Park Units in operation;
- P, Q, V, setpoints and simulated actual voltage level shall be measured for each step; the measurement location depends on the availability of the actual voltage signal; transient measurement equipment will be required to evaluate speed of response and damping of voltage change and voltage/reactive power/power factor response; preferably this should be the Connection Point or the HV side of the step-up transformer.
- Response time of activation;
- A tolerance of max. +/- 5% of the measured value will be accepted.

Test evaluation criteria

In Voltage control mode sub-mode 1 the voltage controller is able to:

- adjust the voltage setpoint such that the reactive power exchange is brought to the reference steady state reactive power exchange within 15 minutes after exceeding the Q dynamic limits;
- hold the reactive power exchange at least 15 minutes after exceeding the Q disturbance limits.

In Voltage control mode sub-mode 2 the voltage controller is able to adjust the reactive power exchange such that it corresponds with the voltage-reactive power slope.

In case of a (O)PPM, the test shall be deemed successful if the following conditions are fulfilled:

- The range of control and adjustable slope (U/Q) and deadband (voltage control mode deadband: an interval used intentionally to make the voltage control unresponsive) complies with the agreed or decided characteristic parameters set out in point (d) of Article 21(3);
 - The slope has been set to 2%;
 - The deadband has been set to zero;
- The insensitivity of voltage control is not higher than 0.01 pu, in accordance with point (d) of Article 21(3);
- The response times according to RfG Article 21(3)(d)(iv) are within the values that are agreed and recorded in the Connection Agreement (ATO).

4.2.11 Reactive power control mode

Applicable to:

	PPM	OPPM			Type C	Type D
--	-----	------	--	--	--------	--------

RfG article: 21(3)(d)

Netcode elektriciteit article: 3.26, sub 6, 9

Test: RfG article 48(8) (PPM, OPPM)

Simulation: none

With regard to the tests referred to in RfG article 48, paragraphs 7, 8 and 9, the relevant system operator may select only one of the three control options (voltage/reactive power/power factor) for testing.

Requirement to be verified

Article 21: Requirements for type C Power Park Modules

3. Type C Power Park Modules shall fulfil the following additional requirements in relation to voltage stability:

(d) with regard to reactive power control modes:

- (i) the Power Park Module shall be capable of providing reactive power automatically by either voltage control mode, reactive power control mode or power factor control mode;
- (v) for the purpose of reactive power control mode, the Power Park Module shall be capable of setting the reactive power setpoint anywhere in the reactive power range, specified by point (a) of Article 20(2) and by points (a) and (b) of Article 21(3), with setting steps no greater than 5 Mvar or 5 % (whichever is smaller) of full reactive power, controlling the reactive power at the Connection Point to an accuracy within plus or minus 5 Mvar or plus or minus 5 % (whichever is smaller) of the full reactive power;
- (vii) the relevant system operator, in coordination with the relevant TSO and with the Power Park Module owner, shall specify which of the above three reactive power control mode options and associated setpoints is to apply, and what further equipment is needed to make the adjustment of the relevant setpoint operable remotely;

Netcode elektriciteit, Article 3.26

6. The Connection Agreement (ATO) stipulates whether automatic reactive power is provided by the PPM, as referred to in RfG Article 21(3)(d), subsection (vii), by means of:
- a. voltage control mode sub-mode 1, where the exchanged reactive power is in an agreed bandwidth, which is also included in the Connection Agreement (ATO),
 - b. voltage control mode sub-mode 2, without requirement regarding the exchanged reactive power,
 - c. reactive power control mode or
 - d. power factor control mode;

9. The priority of the contribution of the active power or the reactive power during interruptions where fault-ride-through capacity is required is location-specific. This option will be agreed upon between the RSO and the connected party, in consultation with the TSO, and will be included in the Connection Agreement (ATO).

Reactive Power Control of (O)PPMs Requirements:

- Reactive Power Control Mode: Reactive Power:
Function: Reactive Power control (Q-control), characterized by, Setpoint Reactive Power and Control Speed.
Input Setpoint: The (O)PPM must have the ability to process the Setpoint Reactive Power indicated by the Network Operator.

Objective

The following requirements shall apply:

- (a) the Power Park Module's capability to operate in reactive power control mode, in accordance with point (v) of Article 21(3)(d), shall be demonstrated;
- (b) the reactive power control mode test shall be complementary to the reactive power capability test;
- (c) the reactive power control mode test shall verify the following parameters:
 - (i) the reactive power setpoint range and increment;
 - (ii) the accuracy of the control; and
 - (iii) the time of reactive power activation.

Reactive power control mode Tests

Test procedure

Starting points:

- The test should be scheduled at a time when there is sufficient MW resource forecasted in order to generate at least 20% of Maximum Capacity of the (O)PPM units in service;
- The test will be executed during normal operation; this means the unit is in steady state operation with a power factor at the Connection Point as determined with the RSO (default value for the reference steady state reactive power exchange is 0 Mvar);
- The setpoint of reactive power control mode may be adjusted remotely or locally in the park-controller in case no remote control is available;
- Q_{max} is the minimum value of the maximum inductive (injected) and maximum capacitive (absorbed) reactive power;
- The tests shall be executed by step-changing the reactive power setpoint in both directions in full range until one of the following restriction applies:

- The maximum absorbed or injected reactive power is reached according to the U-Q/ P_{\max} profile (RfG article 21(3)(b) and Netcode elektriciteit articles 3.19 and 3.33) and P-Q/ P_{\max} profile (RfG article 21(3)(c) and Netcode elektriciteit articles 3.19 and 3.33);
- One of the operational limits of the network of the RSO is reached; this restriction needs to be determined in advance and real time by the RSO; usually a real-time voltage range of 95%-105% of rated voltage applies.

Procedure for Reactive Power Control:

- The Q_{ref} setpoint shall be step-wise changed with steps of 5 Mvar or 10 % related to Q_{\max} (whichever is smaller), in both directions (inductive and capacitive) until one of above mentioned restrictions applies; wait 1 minute after each step
- After completion of the steps in a direction the active power is reduced by 50% and restored to the original value again in order to monitor the reactive power control; wait until the reactive power control stabilises;
- After the maximum reactive power has been reached in one direction, the steps direction reverses and steps will be applied until the maximum reactive power in the opposite direction has been reached.

Documentation/measurements

- Prior to the start of the tests and any changes to the following, if any values change during the tests:
 - All relevant transformer tap positions;
 - Number of Power Park Units in operation;
- P, Q, V and setpoint shall be measured for each step; the measurement location depends on the availability of the setpoint signal; transient measurement equipment will be required to evaluate speed of response and damping of setpoint change and reactive power response; preferably this should be the Connection Point or the HV side of the step-up transformer.
- Response time of activation;
- A tolerance of maximum plus or minus 5 Mvar or plus or minus 5 % of Q_{\max} (whichever is smaller) will be accepted.

Test evaluation criteria

The test shall be deemed successful if the following conditions are fulfilled:

- The reactive power setpoint range and increment are ensured in accordance with point (d) of RfG Article 21(3), concerning Q_{\max} in both directions and the maximum step size;
- The accuracy of the control complies with the conditions set out in point (d) of RfG Article 21(3): the reactive power at the Connection Point to an accuracy within plus or minus 5 Mvar or plus or minus 5 % of Q_{\max} (whichever is smaller) of the full reactive power.

4.2.12 Power factor control mode

Applicable to:

	PPM	OPPM			Type C	Type D
--	-----	------	--	--	--------	--------

RfG article: 21(3)(d)

Netcode elektriciteit article: 3.26, sub 5, 6, 9

Test: RfG article 48(9) (PPM, OPPM)

Simulation: none

With regard to the tests referred to in RfG article 48, paragraphs 7, 8 and 9, the relevant system operator may select only one of the three control options (voltage/reactive power/power factor) for testing.

Requirement to be verified

Article 21: Requirements for type C Power Park Modules

3. Type C Power Park Modules shall fulfil the following additional requirements in relation to voltage stability:

(d) with regard to reactive power control modes:

- (i) the Power Park Module shall be capable of providing reactive power automatically by either voltage control mode, reactive power control mode or power factor control mode;
- (vi) for the purpose of power factor control mode, the Power Park Module shall be capable of controlling the power factor at the Connection Point within the required reactive power range, specified by the relevant system operator according to point (a) of Article 20(2) or specified by points (a) and (b) of Article 21(3), with a target power factor in steps no greater than 0,01. The relevant system operator shall specify the target power factor value, its tolerance and the period of time to achieve the target power factor following a sudden change of active power output. The tolerance of the target power factor shall be expressed through the tolerance of its corresponding reactive power. This reactive power tolerance shall be expressed by either an absolute value or by a percentage of the maximum reactive power of the Power Park Module;
- (vii) the relevant system operator, in coordination with the relevant TSO and with the Power Park Module owner, shall specify which of the above three reactive power control mode options and associated setpoints is to apply, and what further equipment is needed to make the adjustment of the relevant setpoint operable remotely;

Netcode elektriciteit, Article 3.26

5. For the parameters of the power factor control mode of Power Park Modules, as referred to in Article 21, paragraph 3, subsection d, subsection vi of Regulation (EU)

2016/631 (NC RfG), the following applies:

- a. the desired value of the power factor is agreed between the RSO and the connected party, in consultation with the TSO; the agreed value is recorded in the connection agreement (ATO);
 - b. the tolerance of the desired value of the power factor is plus or minus 0.005;
 - c. the time period for reaching the desired value of the power factor after an abrupt change of the active power is agreed between the network operator and the connected party, in consultation with the network operator of the national high-voltage network; the agreed value is recorded in the connection agreement (ATO).
6. The Connection Agreement (ATO) stipulates whether automatic reactive power is provided by the PPM, as referred to in RfG Article 21(3)(d), subsection (vii), by means of:
- a. voltage control mode sub-mode 1, where the exchanged reactive power is in an agreed bandwidth, which is also included in the Connection Agreement (ATO),
 - b. voltage control mode sub-mode 2, without requirement regarding the exchanged reactive power,
 - c. reactive power control mode or
 - d. power factor control mode;
9. The priority of the contribution of the active power or the reactive power during interruptions where fault-ride-through capacity is required is location-specific. This option will be agreed upon between the RSO and the connected party, in consultation with the TSO, and will be included in the Connection Agreement (ATO).

Reactive Power Control Mode: Power Factor

Function: Power Factor control (PF-control), characterized by, Setpoint Power Factor and Control Speed.

Input Setpoint: The (O)PPM must have the ability to process the Setpoint Power Factor indicated by the Network Operator.

Objective

The following requirements shall apply:

- (a) the Power Park Module's capability to operate in power factor control mode in accordance with point (vi) of Article 21(3)(d) shall be demonstrated;
- (b) the power factor control mode test shall verify the following parameters:
 - (i) the power factor setpoint range;
 - (ii) the accuracy of the control; and
 - (iii) the response of reactive power due to step change of active power;

Power factor control mode Tests

Test procedure

Starting points:

- The test should be scheduled at a time when there is sufficient MW resource forecasted in order to generate at least 20% of Maximum Capacity of the (O)PPM units in service;
- The test will be executed during normal operation; this means the unit is in steady state operation with a power factor at the Connection Point as determined with the RSO (default value for the reference steady state reactive power exchange is 0 Mvar); in this case, when the test begins, the power factor at the Connection Point is 1.0;
- The active power output shall be curtailed avoid large uncontrolled reactive power and voltage variations caused by changing wind or solar irradiation conditions;
- The setpoint of reactive power control mode may be adjusted remotely or locally in the park-controller in case no remote control is available;
- Q_{\max} is the minimum value of the maximum inductive (injected) and maximum capacitive (absorbed) reactive power;
- The tests shall be executed by step-changing the setpoint in both directions in full range until one of the following restriction applies:
 - The minimum or maximum reactive power is reached;
 - The maximum absorbed or injected reactive power is reached according to the U-Q/ P_{\max} profile (RfG article 21(3)(b) and Netcode elektriciteit articles 3.19 and 3.33) and P-Q/ P_{\max} profile (RfG article 21(3)(c) and Netcode elektriciteit articles 3.19 and 3.33);
 - One of the operational limits of the network of the RSO is reached; this restriction needs to be determined in advance and real time by the RSO; usually a real-time voltage range of 95%-105% of rated voltage applies.

Procedure for Power Factor Control:

- The Power Factor setpoint shall be step-wise changed with 10 steps per direction between zero reactive power and maximum reactive power in both directions (inductive and capacitive) until one of above mentioned restrictions applies;
- When the maximum reactive power has been reached the active power is reduced by 50% and restored to the original value again in order to monitor the power factor control; wait until the reactive power control stabilises;
- After the maximum reactive power has been reached in one direction, the steps direction reverses and steps will be applied until the maximum reactive power in the opposite direction has been reached.

Documentation/measurements

- Prior to the start of the tests and any changes to the following, if any values change during the tests:

- All relevant transformer tap position;
- Number of Power Park Units in operation;
- P, Q, V and setpoint signal shall be measured for each step; the measurement location depends on the availability of the setpoint signal; transient measurement equipment will be required to evaluate speed of response and damping of setpoint change and voltage/reactive power/power factor response; preferably this should be the Connection Point or the HV side of the step-up transformer.
- Response time of activation;
- A tolerance of maximum plus or minus 5 Mvar or plus or minus 5 % of Q_{\max} (whichever is smaller) will be accepted.

Test evaluation criteria

The test shall be deemed successful if the following conditions are fulfilled:

- The power factor setpoint range and increment are ensured in accordance with point (d) of RfG Article 21(3);
- The time of reactive power activation as a result of step active power change does not exceed the value that is recorded in the connection agreement (ATO);
- The accuracy of the control complies with the conditions set out in point (d) of RfG Article 21(3): the power factor at the Connection Point to an accuracy within plus or minus 0,005;

4.2.13 Island operation (if applicable)

Applicable to:

SPGM	PPM	OPPM			Type C	Type D
------	-----	------	--	--	--------	--------

RfG article: 15(5)(b)

Netcode elektriciteit article: none

Test: none

Simulation: RfG article 52(4) (SPGM), 55(4) (PPM, OPPM)

Requirement to be verified

RfG Article 15: General requirements for type C Power-Generating Modules

5. Type C Power-Generating Modules shall fulfil the following requirements relating to system restoration:

- (b) with regard to the capability to take part in island operation:
 - (i) Power-Generating Modules shall be capable of taking part in island operation if required by the relevant system operator in coordination with the relevant TSO and:
 - the frequency limits for island operation shall be those established in accordance with point (a) of Article 13(1),
 - the voltage limits for island operation shall be those established in accordance with Article 15(3) or Article 16(2), where applicable;
 - (ii) Power-Generating Modules shall be able to operate in FSM during island operation, as specified in point (d) of [RfG Article 15] paragraph 2.
 In the event of a power surplus, Power-Generating Modules shall be capable of reducing the active power output from a previous operating point to any new operating point within the P-Q-capability diagram. In that regard, the Power-Generating Module shall be capable of reducing active power output as much as inherently technically feasible, but to at least 55 % of its maximum capacity;
 - (iii) the method for detecting a change from interconnected system operation to island operation shall be agreed between the Power-Generating Facility Owner and the relevant system operator in coordination with the relevant TSO. The agreed method of detection must not rely solely on the system operator's switchgear position signals;
 - (iv) Power-Generating Modules shall be able to operate in LFSM-O and LFSM-U during island operation, as specified in point (c) of paragraph 2 and Article 13(2);

Objective

The PGM's capability to modulate active power over the full frequency range in island operation shall be demonstrated.

Island operation Simulations

Simulation procedure

- A local external load shall be set with active power equal to the minimum regulating level of the PGM but at least 55% of the maximum capacity and reactive power equal to the maximum leading reactive power capability of the PGM;
- The voltage and frequency of the external network at the Connection Point shall be set as nominal;
- The simulation shall start with normal operation at 90% of Maximum Capacity and no (0 Mvar) reactive power exchange with the external network exclusive the local external load;
- The PGM shall be disconnected, serving only the local load;
- After stabilization the active power of the local load shall be raised to the maximum capability of the PGM and the reactive power shall be raised to the maximum lagging reactive power capability of the PGM (export of reactive power), linearly in time with an agreed ramp;
- After stabilization the reactive power of the external load shall be reduced to maximum leading reactive power capability of the PGM with the agreed time ramp;
- After stabilization the active power of the external load shall be reduced to the minimum regulating level but at least 55% of the maximum capacity and the reactive power of the load to the maximum lagging reactive power capability of the PGM (export of reactive power) linearly with the agreed time ramp.

Simulation evaluation criteria

- The simulation shall be deemed successful if the PGM reduces or increases the active power output from its previous operating point to any new operating point within the P-Q-capability diagram within the limits of point (b) of RfG Article 15(5), without disconnection of the PGM from the island due to over- or underfrequency.

4.2.14 FRT (profiles different B/C and D)

Applicable to:

SPGM	PPM	OPPM		Type B	Type C	Type D
------	-----	------	--	--------	--------	--------

RfG article: 14(3)(a) (type B,C), 16(3)(a) (type D)

Netcode elektriciteit article: 3.17, sub 2 (SPGM type B,C,D voltage below 110kV), 3.17, sub 3 and 7 ((O)PPM type B,C,D voltage below 110kV), 3.28 sub 2 (SPGM type D at 110kV and higher), 3.28, sub 3 and 5 ((O)PPM type D at 110kV and higher)

Test: required by RSO; not according to RfG

Simulation: RfG article 51(3) (SPGM type B,C), 54(4) (PPM type B,C), 53.3 (SPGM type D), 56.3 (PPM type D, OPPM)

Requirement to be verified

RfG Article 14(3)(a): type B, C SPGM and PPM (and type D SPGM and PPM below 110kV)

- (i) Each TSO shall specify a voltage-against-time-profile in line with [RfG] Figure 3 at the Connection Point for fault conditions, which describes the conditions in which the Power-Generating Module is capable of staying connected to the network and continuing to operate stably after the power system has been disturbed by secured faults on the transmission system;
- (ii) The voltage-against-time-profile shall express a lower limit of the actual course of the phase-to-phase voltages on the network voltage level at the Connection Point during a symmetrical fault, as a function of time before, during and after the fault;
- (iii) The lower limit referred to in point (ii) shall be specified by the relevant TSO using the parameters set out in [RfG] Figure 3, and within the ranges set out in [RfG] Tables 3.1 and 3.2;

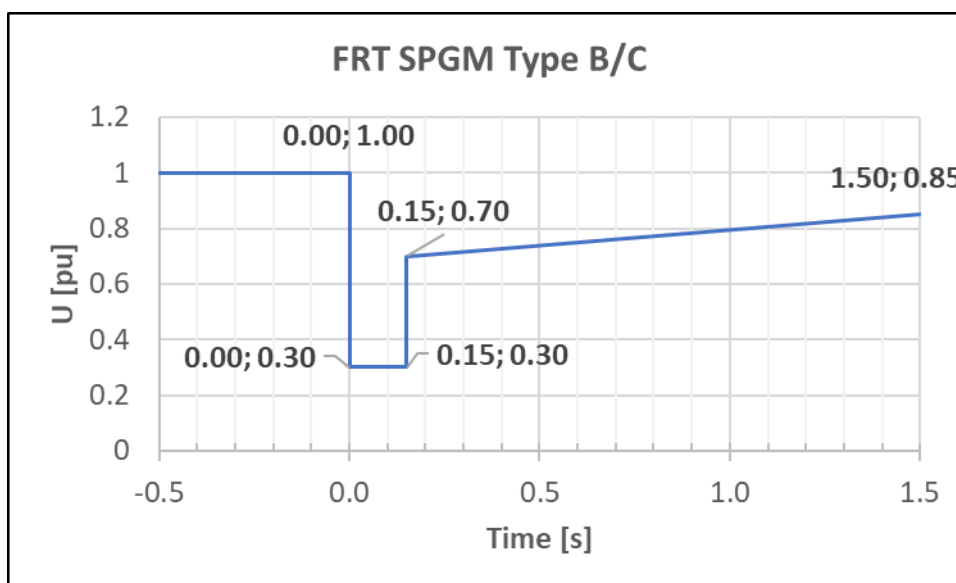

Figure 4.19 Fault-ride-through profile of a type B/C SPGM

RfG Table 3.1 Parameters for RfG Figure 3 for fault-ride-through capability of SPGM's, as specified in Netcode elektriciteit Article 3.17 sub 2

Voltage parameters [p.u.]		Time parameters [s]	
U_{ret}	0.3	t_{clear}	0.15
U_{clear}	0.70	t_{rec1}	t_{clear}
U_{rec1}	U_{clear}	t_{rec2}	t_{rec1}
U_{rec2}	0.85	t_{rec3}	1.5

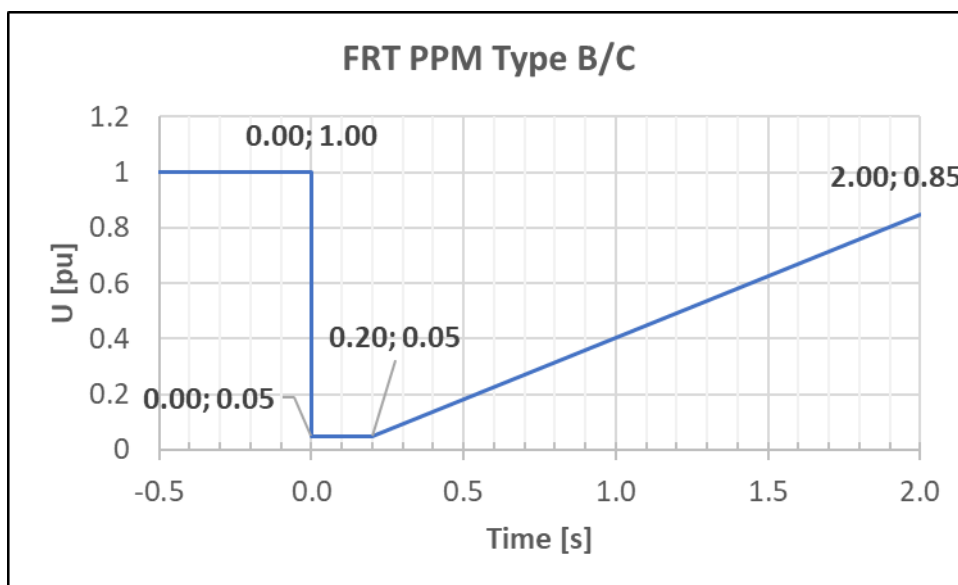

Figure 4.20 Fault-ride-through profile of a type B/C PPM

RfG Table 3.2 Parameters for RfG Figure 3 for fault-ride-through capability of PPM's, as specified in Netcode elektriciteit Article 3.17 sub 3

Voltage parameters [p.u.]		Time parameters [s]	
U_{ret}	0.05	t_{clear}	0.2
U_{clear}	U_{ret}	t_{rec1}	t_{clear}
U_{rec1}	U_{clear}	t_{rec2}	t_{rec1}
U_{rec2}	0.85	t_{rec3}	2.0

- (iv) Each TSO shall specify and make publicly available the pre-fault and post-fault conditions for the fault-ride-through capability in terms of:
- the calculation of the pre-fault minimum short circuit capacity at the connection point,
 - pre-fault active and reactive power operating point of the power-generating module at the connection point and voltage at the connection point, and

- calculation of the post-fault minimum short circuit capacity at the connection point;
- (v) At the request of a power-generating facility owner, the relevant system operator shall provide the pre-fault and post-fault conditions to be considered for fault-ride-through capability as an outcome of the calculations at the connection point as specified in point (iv) regarding:
- pre-fault minimum short circuit capacity at each connection point expressed in MVA,
 - pre-fault operating point of the power-generating module expressed in active power output and reactive power output at the connection point and voltage at the connection point, and
 - post-fault minimum short circuit capacity at each connection point expressed in MVA.

Alternatively, the relevant system operator may provide generic values derived from typical cases;

- (vi) the power-generating module shall be capable of remaining connected to the network and continuing to operate stably when the actual course of the phase-to-phase voltages on the network voltage level at the connection point during a symmetrical fault, given the pre-fault and post-fault conditions in points (iv) and (v) of [NC RfG article 14] paragraph 3(a), remain above the lower limit specified in point (ii) of [NC RfG article 14] paragraph 3(a), unless the protection scheme for internal electrical faults requires the disconnection of the power-generating module from the network. The protection schemes and settings for internal electrical faults must not jeopardise fault-ride-through performance;
- (vii) without prejudice to point (vi) of [NC RfG article 14] paragraph 3(a), undervoltage protection (either fault-ride-through capability or minimum voltage specified at the connection point voltage) shall be set by the power-generating facility owner according to the widest possible technical capability of the power-generating module, unless the relevant system operator requires narrower settings in accordance with point (b) of [NC RfG article 14] paragraph 5. The settings shall be justified by the power-generating facility owner in accordance with this principle;

RfG Article 14(3)(b)

Fault-ride-through capabilities in case of asymmetrical faults shall be specified by each TSO.

Netcode elektriciteit Article 3.17, sub 7:

The fault-ride-through capability in case of asymmetric disturbances, as referred to in Article 14(3)(b) of Regulation (EU) 2016/631 (NC RfG), is identical to the fault-ride-through capability in case of symmetric disturbances.

RfG Article 16(3)(a): type D SPGM and PPM

- (i) Power-generating modules shall be capable of staying connected to the network and

continuing to operate stably after the power system has been disturbed by secured faults. That capability shall be in accordance with a voltage-against-time profile at the Connection Point for fault conditions specified by the relevant TSO.

The voltage-against-time-profile shall express a lower limit of the actual course of the phase-to-phase voltages on the network voltage level at the Connection Point during a symmetrical fault, as a function of time before, during and after the fault.

That lower limit shall be specified by the relevant TSO, using the parameters set out in [RfG] Figure 3 and within the ranges set out in [RfG] Tables 7.1 and 7.2 for type D Power-Generating Modules connected at or above the 110 kV level.

That lower limit shall also be specified by the relevant TSO, using parameters set out in [RfG] Figure 3 and within the ranges set out in [RfG] Tables 3.1 and 3.2 [PGM type B] for type D Power-Generating Modules connected below the 110 kV level;

- (ii) Each TSO shall specify the pre-fault and post-fault conditions for the fault-ride-through capability referred to in point (iv) of [RfG] Article 14(3)(a). The specified pre-fault and post-fault conditions for the fault-ride-through capability shall be made publicly available;

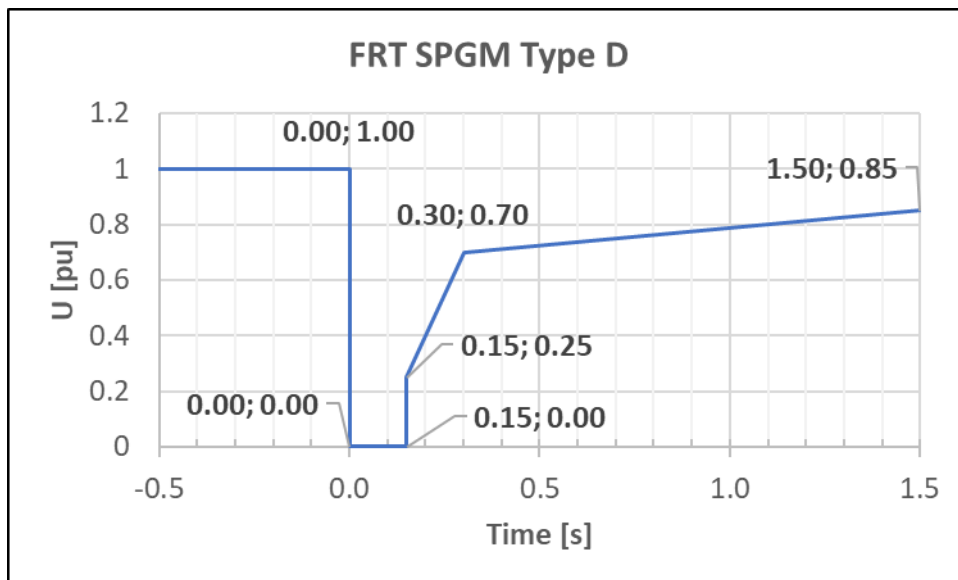

Figure 4.21 Fault-ride-through profile of a type D SPGM

RfG Table 7.1 Parameters for RfG Figure 3 for fault-ride-through capability of SPGM's, as specified in Netcode elektriciteit Article 3.28 sub 2

Voltage parameters [p.u.]		Time parameters [s]	
U_{ret}	0	t_{clear}	0.15
U_{clear}	0.25	t_{rec1}	0.3
U_{rec1}	0.70	t_{rec2}	t_{rec1}
U_{rec2}	0.85	t_{rec3}	1.5

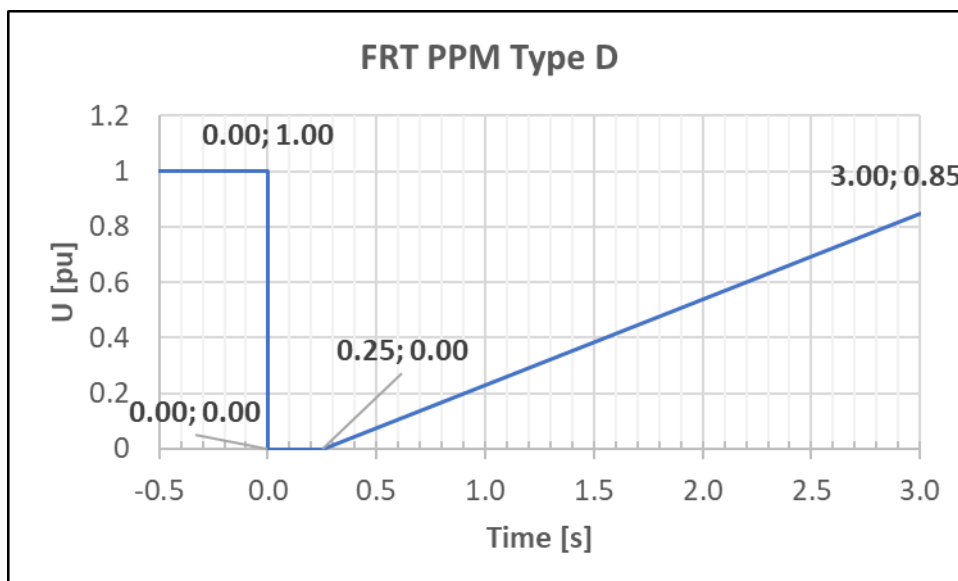

Figure 4.22 RfG Figure 3 Fault-ride-through profile of a type D PPM

RfG Table 7.2 Parameters for RfG Figure 3 for fault-ride-through capability of PPM's, as specified in Netcode elektriciteit Article 3.28 sub 3

Voltage parameters [p.u.]		Time parameters [s]	
U_{ret}	0	t_{clear}	0.25
U_{clear}	U_{ret}	t_{rec1}	t_{clear}
U_{rec1}	U_{clear}	t_{rec2}	t_{rec1}
U_{rec2}	0.85	t_{rec3}	3.0

RfG Article 16(3)(c):

Fault-ride-through capabilities in case of asymmetrical faults shall be specified by each TSO.

Netcode elektriciteit Article 3.28, sub 5:

The fault-ride-through capability in case of asymmetric disturbances, as referred to in Article 16(3)(c) of Regulation (EU) 2016/631 (NC RfG), is identical to the fault-ride-through capability in case of symmetric disturbances.

RfG Article 26(2): Robustness requirements applicable to AC-connected offshore Power Park Modules

The fault-ride-through capability requirements laid down in point (a) of [RfG] Article 14(3) (PGM type B) and point (a) of [RfG] Article 16(3) (PGM type D) shall apply to AC-connected offshore Power Park Modules.

Similar to [RfG] Article 16(3) sub a(i), for an offshore PPM connected below the 110 kV level, RfG Article 14(3) sub a will apply.

Netcode elektriciteit article 3.32 sub 3 refers to Netcode elektriciteit article 3.17, sub 3 for OPPM connected to a network with voltage below 110kV, stipulating that the fault-ride-through profile of a PPM type B/C applies (figure 4.20).

Objective

The objective is to prove the fault-ride-through capability of the PGM according to RfG and Netcode elektriciteit requirements.

FRT Test for a type D Synchronous Power-Generating Module

Objective

- The FRT capability of type D SPGM is demonstrated by means of testing the robustness of the SPGM auxiliary system to voltage dips

The test consists of opening the main auxiliary switch during a specific time and at specific voltage conditions in order to prove that the auxiliary system is capable to withstand a long duration voltage drop. The duration of opening the main auxiliary switch is a summation of:

- The maximum short-circuit duration for type D PGM: 150 ms;
- The duration of the voltage to recover to 85% after clearing a network short-circuit;
- The detection time of the minimum-voltage protection when the voltage recovers;
- The minimum-voltage protection time delay setting;
- The switching time of the PGM connection switch;
- The generator voltage recovery time.

Test procedure

- The SPGM output active power at the Connection Point shall be at least 80% of P_{max} ;
- The SPGM output reactive power at the Connection Point shall be set according to the value that will be agreed between the Power-Generation Facility Owner and the relevant system operator;
- While in stable operation the SPGM's auxiliary system main switch will be opened;
- The moment that the auxiliary system main busbar voltage is 70% of the nominal value or less, will be recorded;
- At least 1.5 s after the auxiliary system main busbar voltage is 70% of the nominal value or less, the auxiliary system main switch will be closed;
- The test ends when the SPGM operates in a stable manner during at least 15 minutes and does not disconnect due to this test.

Documentation/measurements

To the relevant system operator will be reported:

- Time of start and end of test;
- Auxiliary main busbar voltage as stored data as time profile;
- Connection Point active and reactive output power as stored data as time profile.

Evaluation criteria

- During the test the SPGM stays connected to the network and continues to operate stably after the test.

FRT Test for a PPM and OPPM Generating Unit

Objective

- Proof of compliance with fault-ride-through of the (O)PPM Generating Unit according to RfG articles 14(3) and 16(3) and to Netcode elektriciteit article 3.17, sub 3 and article 3.28 sub 3.
- To validate the (O)PPM Generating Unit and FACTS models.

The tests shall be performed as a type test, either by an independent test institute or by the manufacturer. If the type tests are performed by the manufacturer, they need to be witnessed and approved by an independent test institute. The type tests may be executed together with the fast fault current injection tests for a PPM and OPPM Generating Unit.

Tests shall be executed as a type test according to FGW TG3-2018 Rv. 25. In deviation from FGW TG3-2018 Rv. 25 the tests shall be executed for the following minimum fault scenarios:

- Type B/C: fault residual voltage 5% of rated voltage, fault duration 200 ms;
- Type D: fault residual voltage lower than 5% of rated voltage, fault duration 250 ms;
- Type B/C: fault voltage between 40% and 50% of rated voltage, fault duration 1200 ms;
- Type D: fault voltage between 40% and 50% of rated voltage, fault duration 1800 ms;
- Type B/C: fault voltage between 70% and 80% of rated voltage, fault duration 1900 ms.
- Type D: fault voltage between 70% and 80% of rated voltage, fault duration 2800 ms.

The fault voltage corresponds to the FRT-profile on the connection point. For the test on generating unit level, a correction for transformer and cables is allowed.

The tests shall be executed for an active power output of the (O)PPM generating unit of 20% to 35% and higher than 80% of maximum capacity respectively.

Tests shall be executed for symmetrical and unsymmetrical (phase to phase) faults. The applied k-factor shall be as mentioned in FGW TG3-2018 Rv. 25 . In case of a DFIG wind turbine the k-factor shall be agreed with the RSO.

FRT Simulations

Objective

- Proof of compliance with fault-ride-through of the PGM according to RfG articles 14(3) and 16(3) and to Netcode elektriciteit article 3.17, sub 2 and 3 and article 3.28 sub 2 and 3.

In case of a PPM type B a number of simplifications may be applied. Regarding fault-ride-through and fast fault current injection, generating units are type tested on these requirements. If for these requirements unit certificates are available for all generating units in the PPM, simulations to prove compliance with these requirements will not be required by the RSO.

Simulation procedure

The simulation will be executed by simulating three-phase voltage dips large enough and with duration long enough to prove the fault-ride through capability of the PGM.

- Simulation of fault-ride-through profile at Connection Point according to RfG articles 14(3) and 16(3);
- The pre-fault and post-fault conditions for the fault-ride-through capability referred to in point (iv) of Article 14(3)(a) shall be specified by the RSO;
- Three-phase faults will be tested; in case of an (O)PPM also asymmetrical (1- and 2-phase) faults will be tested;
- The simulations will be executed for a reactive power output Q/P_{max} of 0%;
- For Power Park Module Units the k-factor should be set to 5; when connected at a grid voltage of 66kV or higher and 2 when connected below 66kV . Based on the simulation results (additional reactive current, voltage dip) the k-factor at the Connection Point shall be calculated for a three-phase fault according to the definition and equation given in Netcode elektriciteit article 3.19 sub 10; in case of a DFIG wind turbine the k-factor shall be equal to the value used in the test;
- For a residual voltage lower than 10% at the generating unit terminals the active and reactive current evaluation may be excluded.

Power Generating Modules types B and C and type D PGM's connected at voltage lower than 110kV:

Synchronous Power-Generating Module:

- The simulations shall be executed for active power output: 100% of P_{max} ;
- The simulation scenarios are:

- Fault residual voltage 5% of nominal voltage; fault duration at least 150 ms;
- Fault residual voltage 70% of nominal voltage; fault duration at least 150 ms;
- Fault residual voltage 75% of nominal voltage; fault duration at least 600 ms;
- Fault residual voltage 80% of nominal voltage; fault duration at least 1050 ms;
- Fault residual voltage 85% of nominal voltage; fault duration at least 1500 ms.

(Offshore) Power Park Module:

- The simulations shall be executed for active power output: 100% of P_{max}
- The simulation scenarios are:
 - Fault residual voltage 5% of nominal voltage; fault duration at least 200 ms;
 - Fault residual voltage 20% of nominal voltage; fault duration at least 540 ms;
 - Fault residual voltage 40% of nominal voltage; fault duration at least 990 ms;
 - Fault residual voltage 60% of nominal voltage; fault duration at least 1440 ms;
 - Fault residual voltage 85% of nominal voltage; fault duration at least 2000 ms.

Power Generating Modules type D connected at voltages equal to 110kV and higher:

Synchronous Power-Generating Module:

- The simulations shall be executed for active power output: 100% of P_{max} ;
- The simulation scenarios are:
 - Fault residual voltage lower than 5% of nominal voltage; fault duration at least 150 ms;
 - Fault residual voltage 25% of nominal voltage; fault duration at least 150 ms;
 - Fault residual voltage 70% of nominal voltage; fault duration at least 300 ms;
 - Fault residual voltage 75% of nominal voltage; fault duration at least 700 ms;
 - Fault residual voltage 80% of nominal voltage; fault duration at least 1100 ms;
 - Fault residual voltage 85% of nominal voltage; fault duration at least 1500 ms.

(Offshore) Power Park Module:

- The simulations shall be executed for active power output: 100% of P_{max}
- The simulation scenarios are:
 - Fault residual voltage lower than 5% of nominal voltage; fault duration at least 420 ms;
 - Fault residual voltage 20% of nominal voltage; fault duration at least 900 ms;
 - Fault residual voltage 40% of nominal voltage; fault duration at least 1550 ms;
 - Fault residual voltage 60% of nominal voltage; fault duration at least 2200 ms;
 - Fault residual voltage 85% of nominal voltage; fault duration at least 3000 ms.

Documentation / calculated parameters

- At the Connection Point: power (P, Q), Voltage (V), Current (I) as function of time;
- For Power Park Module Units:
 - Applied parameter settings of generating unit and park controller models;
 - Calculated k-factor at the Generating Unit and values including time step applied (for faults with residual voltage > 0,15 pu).

Simulation evaluation criteria

The test simulation be deemed successful if the following conditions are fulfilled:

- The PGM is capable to fault-ride-through according to the requirements;
- In case of a PPM, k-factor according to controller setting.

4.2.15 Reconnecting after disconnection

Applicable to:

SPGM	PPM	OPPM		Type B	Type C	Type D
------	-----	------	--	--------	--------	--------

RfG article: 14(4)(a)

Netcode elektriciteit article: 3.20

Test: required by RSO; not according to RfG

Simulation: none

Requirement to be verified

If a Power-Generating Module is capable of reconnecting to the network after an incidental disconnection caused by a network disturbance.

RfG Article 14: General requirements for type B Power-Generating Modules; also applicable to types C and D.

4. Type B Power-Generating Modules shall fulfil the following requirements relating to system restoration:

- (a) the relevant TSO shall specify the conditions under which a Power-Generating Module is capable of reconnecting to the network after an incidental disconnection caused by a network disturbance; and
- (b) installation of automatic reconnection systems shall be subject both to prior authorisation by the relevant system operator and to the reconnection conditions specified by the relevant TSO.

Netcode elektriciteit, article 3.17, sub 8:

The Power-Generating Module is capable of connecting to the grid after a fault, as referred to in Article 14(4), under a, of Regulation (EU) 2016/631 (NC RfG), if:

- (a) the voltage is higher than or equal to 0,9 pu and lower than or equal to 1,1 pu;
- (b) the frequency is higher than or equal to 47.5 Hz and lower than or equal to 51.0 Hz if the reconnection process is initiated manually;
- (c) the frequency is higher than or equal to 49.9 Hz and lower than or equal to 50.1 Hz if the reconnection is executed automatically;
- (d) the time that voltage and frequency are within the ranges stated in (a) and (b) is at least 60 seconds;
- (e) the maximum ramp of active power increase is 20% of the maximum capacity per minute.

Netcode elektriciteit article 3.20:

Sub 1: When the Power-Generating Module with a maximum capacity larger than 5 MW, connected to a medium or high voltage grid, is disconnected from the grid by a short circuit in the grid and the grid voltage returns within 60 minutes, the Power-Generating Module shall be able to operate stably in parallel with the grid with all

generating units in operation within 30 minutes of the return of the grid voltage.

Sub 2: When the period of 30 minutes, mentioned at sub 1, is technically not feasible, the facility owner must explain this to the transmission grid operator. It must also be stated to the transmission grid operator within what time the stable operation referred to in the first paragraph is possible in that case.

Objective

The objective is to prove the capability of the PGM to reconnect after disconnection from the network according to RfG and Netcode elektriciteit requirements.

Reconnecting after disconnection Tests

Test procedure

For Synchronous Power-Generating Modules type C and D the test can be executed together with the Tripping to Household test. For all PGM's types B, C and D the procedure is as follows:

- In case of an SPGM the active power output is at least 85% of P_{max} ;
- In case of a PPM the active power output is at least 50% of P_{max} ;
- The tests will be executed with a suitable reactive power output between 0 Mvar and maximum reactive power output Q/P_{max} which shall be selected in consultation with the relevant system operator, taking impact on network voltage upon disconnection into account;
- The PGM with a maximum capacity larger than 5 MW, connected to a medium or high voltage grid shall operate stable in parallel with the grid with all generating units in operation within 30 minutes of the return of the grid voltage. The facility owner must explain to the grid operator when the period of 30 minutes is technically not feasible and what time is feasible.
- The facility owner shall inform the relevant system operator on the reconnection procedure/process of the PGM; manually or automatic reconnection of generating units; reconnection sequence and times circuit breakers of generator unit transformers (inrush current can be high when all transformers are energized at the same time);
- The PGM (SPGM and PPM) will be disconnected from the network by tripping the circuit breaker at the point of connection; also connections to the low voltage network for auxiliary supplies and controls will be tripped; optionally for windfarms, disconnection can be preceded by tripping one of the wind turbines of each type by operating the under voltage or underfrequency protection of that wind turbine. All other wind turbines can then be taken out of operation in a controlled way before tripping the circuit breaker at the point of connection;
- When a separate grid connection is used for auxiliary or control system supplies, this grid connection shall also be disconnected at the moment that the main connection

is disconnected.

- In case of an SPGM type C and D, the SPGM will successfully go into houseload operation and will run stable for 1 hr;
- In case of an SPGM type C and D:
 - 1 hr after disconnection the PGM will be synchronised and reconnected to the network;
 - Within 30 minutes after synchronisation the PGM will be able to operate stable at Minimum Regulating Level;
 - After reaching the Minimum Regulating Level, the PGM will be able to run stable at minimum regulating level for 1 hr;
 - The active power output will gradually increase to at least 85% of P_{max} ;
 - The maximum ramp rate is 20% of P_{max} per minute;
- In case of an SPGM type B or PPM:
 - 15 minutes after disconnection the PGM will be reconnected to the network by closing the circuit breaker at the point of connection; when manual reconnection of circuit breakers of generating unit transformers is required, these circuit breakers shall be tripped automatically when disconnected from the network
 - The active power output will gradually increase to at least 50% of P_{max} ;
 - The maximum ramp rate is 20% of P_{max} per minute.

Documentation/measurements

The following signals will be reported as time functions:

- At the Connection Point: power (P, Q), Voltage (V), Current (I);
- Synchronisation of units.

Test evaluation criteria

The test is deemed successful if the following conditions are fulfilled:

- The PGM runs stable during the whole test;
- After reconnection the active power output increases by no more than the maximum ramp rate.
- After the grid voltage has returned, and if $P_{max} > 5$ MW, the PGM shall be up and running again within 30 minutes after return of the voltage.

4.2.16 Post fault active power recovery

Applicable to:

SPGM	PPM	OPPM		Type B	Type C	Type D
------	-----	------	--	--------	--------	--------

RfG article: 17(3) (SPGM), 20(3) (PPM, OPPM)

Netcode elektriciteit article: 3.18 (SPGM), 3.19, sub 10 and 13 (PPM, OPPM)

Test: none

Simulation: RfG article 51(4) (SPGM), 54(5) (PPM, OPPM)

Requirement to be verified

RfG Article 17: Requirements for type B synchronous Power-Generating Modules; also applicable to types C and D

3. With regard to robustness, type B synchronous Power-Generating Modules shall be capable of providing post-fault active power recovery. The relevant TSO shall specify the magnitude and time for active power recovery.

RfG Article 20 Requirements for type B Power Park Modules; also applicable to types C and D

3. Type B Power Park Modules shall fulfil the following additional requirements in relation to robustness:

- (a) the relevant TSO shall specify the post-fault active power recovery that the Power Park Module is capable of providing and shall specify:
 - (i) when the post-fault active power recovery begins, based on a voltage criterion;
 - (ii) a maximum allowed time for active power recovery; and
 - (iii) a magnitude and accuracy for active power recovery;
- (b) the specifications shall be in accordance with the following principles:
 - (i) interdependency between fast fault current requirements (according to points (b) and (c) of RfG 20(2)) and active power recovery;
 - (ii) dependence between active power recovery times and duration of voltage deviations;
 - (iii) a specified limit of the maximum allowed time for active power recovery;
 - (iv) adequacy between the level of voltage recovery and the minimum magnitude for active power recovery; and
 - (v) adequate damping of active power oscillations.

Netcode elektriciteit article: 3.18 sub 5 (SPGM)

The SPGM is capable of supplying the amount of active power prior to the failure as soon as possible after a fault.

Netcode elektriciteit Article 3.19, sub 10 (PPM) and accordingly applied to in Article 3.33, sub 5 (OPPM): The power park module is capable of providing fast fault current at the connection point in case of symmetrical (3-phase) faults, as referred to in NC RfG article 20(2)(b) under the following conditions:

- a. Additional reactive current injection shall be activated in the event of the occurrence of a sudden change of the measured instantaneous sinusoidal voltage with system frequency with respect to the sustained instantaneous voltage before the occurrence of the fault of at least 5% of the peak value of the nominal voltage or in the event of a deviation of at least 10% of the effective value of the voltage at the connection point of the generating unit.

Netcode elektriciteit article: 3.19, sub 13 (PPM, OPPM via 3.32 sub 3)

11. The Power Park Module is able to restore the active power as quickly as possible after a fault. The minimum requirements are:
- a. the recovery of the active power starts at a voltage level of 90% of the voltage before the fault;
 - b. the maximum allowed time for the recovery of the active power is between 0.5 and 10 seconds;
 - c. the magnitude for the recovery of the active power is at least 90% of the power before the fault;
 - d. the accuracy of the restored active power is 10% of the power before the fault.

Objective

The objective is to prove the capability of the PGM to provide post fault active power recovery according to RfG and Netcode elektriciteit requirements.

Post fault active power recovery Simulations

Objective

This simulation focusses on PGM's capability to recover its active power within a short time after fault-ride-through performance.

In the case of a PPM type B the following simplifications may be applied:

- Regarding post fault active power recovery: generating units are type tested on these requirements; if for these requirements unit certificates are available for all generating units in the PPM, simulations to prove compliance with these requirements will not be required by the RSO.

Simulation procedure

All fault-ride-through simulations and results shall include the active power recovery after the fault is cleared.

The simulation will be executed by simulating three-phase voltage dips large enough and with duration long enough to prove the fault-ride through capability of the PGM.

- Simulation of voltage dips as described in the paragraph 4.2.14.2 on fault-ride-through;
- Three-phase faults will be simulated;
- The simulations will be executed for a reactive power output Q/P_{\max} of 0%;
- For Power Park Module Units the k-factor should be set to 4; based on the simulation results (additional reactive current, voltage dip) the k-factor at the Connection Point shall be calculated for a three-phase fault according to the definition and equation given in Netcode elektriciteit article 3.19 sub 10. In case of a

DFIG wind turbine the k-factor shall be agreed with the RSO.

The simulations will be executed as described in the paragraph on fault-ride-through for:

- Synchronous Power Generating Modules types B and C and type D PGM's connected at voltage lower than 110kV
- (Offshore) Power Park Modules types B and C and type D PGM's connected at voltage lower than 110kV
- Synchronous Power Generating Modules types B and C and type D PGM's connected at voltage equal to 110kV and higher
- (Offshore) Power Park Modules types B and C and type D PGM's connected at voltage equal to 110kV and higher

Documentation / calculated parameters

- At the Connection Point: power (P, Q), Voltage (V), Current (I) as function of time;
- For Power Park Module Units:
 - Applied parameter settings of generating unit and park controller models;
 - Calculated k-factor at the Generating Unit and values including time step applied.

Simulation evaluation criteria

The simulation is deemed successful if the following conditions are fulfilled:

- SPGM: the post fault active power recovery is as soon as possible; this is an expert judgement
- PPM and OPPM: the post fault active power has recovered to at least 90% of the pre-fault magnitude within 10 s after clearance of the fault.

4.2.17 Power Oscillation Damping Control (POD) (if applicable)

Applicable to:

SPGM	PPM	OPPM			Type C	Type D
------	-----	------	--	--	--------	--------

RfG article: 19(2), 21(3)(f)

Netcode elektriciteit article: 3.29, sub 2 (SPGM),

Type: C, D for PPM; type D for SPGM

Test: none

Simulation: RfG article 53(2) (SPGM), 55(7) (PPM, OPPM)

Requirement to be verified

RfG Article 19: Requirements for type D synchronous Power-Generating Modules

2. Type D synchronous Power-Generating Modules shall fulfil the following additional requirements in relation to voltage stability:

(a) the parameters and settings of the components of the voltage control system shall be

- agreed between the Power-Generating Facility Owner and the relevant system operator, in coordination with the relevant TSO;
- (b) the agreement referred to in subparagraph (a) shall cover the specifications and performance of an automatic voltage regulator ('AVR') with regard to steady-state voltage and transient voltage control and the specifications and performance of the excitation control system. The latter shall include:
- (i) bandwidth limitation of the output signal to ensure that the highest frequency of response cannot excite torsional oscillations on other Power-Generating Modules connected to the network;
 - (ii) an underexcitation limiter to prevent the AVR from reducing the alternator excitation to a level which would endanger synchronous stability;
 - (iii) an overexcitation limiter to ensure that the alternator excitation is not limited to less than the maximum value that can be achieved whilst ensuring that the synchronous Power-Generating Module is operating within its design limits;
 - (iv) a stator current limiter; and
 - (v) a PSS function to attenuate power oscillations, if the synchronous Power-Generating Module size is above a value of maximum capacity specified by the relevant TSO.

RfG Article 21: Requirements for type C Power Park Modules

3. Type C Power Park Modules shall fulfil the following additional requirements in relation to voltage stability:

- (f) with regard to power oscillations damping control, if specified by the relevant TSO a Power Park Module shall be capable of contributing to damping power oscillations. The voltage and reactive power control characteristics of Power Park Modules must not adversely affect the damping of power oscillations.

According to Netcode elektriciteit Article 3.29, sub 6 (PGM type D):

The SPGM, connected to a network with nominal voltage of 220 kV and higher, will be equipped with a PSS-function to damp power oscillations.

Referring to RfG article 21(3)(f) the PPM shall be capable of contributing to damping power oscillations if this is specified by the RSO. In that case it will be recorded in the ATO.

Objective

With regard to the power oscillations damping control simulation:

- It shall be demonstrated that the SPGM's performance in terms of its control system ('PSS function') is capable of damping active power oscillations in accordance with the conditions set out in paragraph 2 of Article 19;
- The model of the PPM shall demonstrate that it can provide active power oscillations damping capability accordance with point (f) of Article 21(3).

POD Simulations

Simulation procedure

The time domain simulation studies shall be performed using an equivalent dynamic model of the network where the specific modes that are to be damped are observable.

The control principle of the POD function is location specific, therefore the details of the simulation studies are defined only after this control principle has been determined.

In general, the simulation studies are carried out:

- For minimum and maximum short-circuit levels;
- With the POD function active and not active;
- For operation at maximum and minimum active power;
- With maximum and minimum reactive power exchange;
- The events to be evaluated are defined on a case by case basis, for example active power steps and reactive power steps.

The frequency domain simulations are defined on a case by case basis.

Documentation / calculated parameters

As a minimum the following signals from the simulations shall be recorded for evaluation:

- Active and reactive power at the connection point;
- Voltage and current at the connection point;
- Network frequency;
- POD output;
- Activation of limiters and electrical protections;
- Additional signals can be specified depending on the control principle of the POD function.

The documentation of the frequency domain simulations is defined on a case by case basis.

Simulation evaluation criteria

The time domain simulation shall be deemed passed, provided that the following conditions are cumulatively fulfilled:

- The POD function results in a positive contribution to the damping of the existing power oscillation, in comparison to the situation without the POD function;
- A change of active or reactive power transfer of the DC-connected PPM as specified by the relevant TSO does not lead to undamped oscillations in active or reactive power of the DC-connected PPM;
- The DC-connected PPM does not cause undamped active or reactive power oscillations in the AC network that did not exist without the DC-connected PPM;
- The POD function does not exceed the specified maximum contribution for damping;
- The damping control function can be enabled and disabled manually;
- The damping control parameters can be altered.

The frequency domain simulation criteria are defined on a case by case basis.

4.2.18 Fast fault current injection

Applicable to:

	PPM	OPPM		Type B	Type C	Type D
--	-----	------	--	--------	--------	--------

RfG article: 20(2)(b,c)

Netcode elektriciteit article: 3.19, sub 10, 11, 12, article 3.33, sub 5

Test: required by RSO; not according to RfG

Simulation: RfG article 54(3) (PPM, OPPM)

Requirement to be verified

RfG Article 20(2): Requirements for type B Power Park Modules

RfG Article 25(4) offshore PPM

2. Type B Power Park Modules shall fulfil the following additional requirements in relation to voltage stability:
- (a) with regard to reactive power capability, the relevant system operator shall have the right to specify the capability of a Power Park Module to provide reactive power;
 - (b) the relevant system operator in coordination with the relevant TSO shall have the right to specify that a Power Park Module be capable of providing fast fault current at the Connection Point in case of symmetrical (3-phase) faults, under the following conditions:
 - (i) the Power Park Module shall be capable of activating the supply of fast fault current either by:
 - ensuring the supply of the fast fault current at the Connection Point, or
 - measuring voltage deviations at the terminals of the individual units of the Power Park Module and providing a fast fault current at the terminals of these units;
 - (ii) the relevant system operator in coordination with the relevant TSO shall specify:
 - how and when a voltage deviation is to be determined as well as the end of the voltage deviation,
 - the characteristics of the fast fault current, including the time domain for measuring the voltage deviation and fast fault current, for which current and voltage may be measured differently from the method specified in RfG Article 2,
 - the timing and accuracy of the fast fault current, which may include several stages during a fault and after its clearance;
 - (c) with regard to the supply of fast fault current in case of asymmetrical (1-phase or 2-phase) faults, the relevant system operator in coordination with the relevant TSO shall have the right to specify a requirement for asymmetrical current injection.

Netcode elektriciteit Article 3.19, sub 10 and accordingly applied to in Article 3.33, sub 5: The power park module is capable of providing fast fault current at the connection point in case of symmetrical (3-phase) faults, as referred to in NC RfG article 20(2)(b) under the following conditions:

- a. Additional reactive current injection shall be activated in the event of the occurrence of either one of the following events at the terminals of the individual generating units of the power park module:
 - 1°. a deviation of more than 10% of the RMS value of the nominal voltage; or
 - 2°. a sudden change in the instantaneous sinusoidal voltage before the occurrence of the fault of at least 5% of the peak value of the nominal voltage [see figure 4.23 for an example];
- b. The voltage control shall ensure the supply of additional reactive current, originating from the terminals of the individual generating units, of at least 2% and at most 6% of the rated current per percent of the voltage deviation;
- c. The rise time (the time after fault inception that is needed for the additional reactive current to be injected to reach a value of 90% of the stable end value) shall be at most 30 ms; the settling time (the time after fault inception that is needed for the additional reactive current to be injected to be permanently between 90% and 110% of the stable final value) shall be at most 60 ms [see figure 4.24];
- d. Additional reactive current injection shall be supplied up to a voltage limit of minimal 120% rated generating unit voltage;
- e. The additional reactive current to be injected (defined as the difference of the reactive current during the fault (I_B) and the pre-fault reactive current (I_{B0})) shall be proportional to the voltage drop as follows:

$$\Delta I_B = ((U - U_0) / U_N) * I_N * k$$

Where:

ΔI_B : additional reactive current during fault = ($I_B - I_{B0}$);

I_B : reactive current during fault;

I_{B0} : pre-fault reactive current;

and:

$(U - U_0) / U_N$: Voltage Drop;

U : Voltage during fault;

U_0 : pre-fault Voltage (one-minute average value);

U_N : rated Voltage;

I_N : rated current;

k : factor for additional reactive current injection;

- f. The adjustment range for k shall be $2 \leq k \leq 6$;
- g. Adjustment step for k less or equal to 0.5;
- h. the default value of k is 2 for a power park module connected to a network with a nominal voltage lower than 66 kV and the default value of k is 5 for a power park module connected to a network with a nominal voltage of 66 kV and higher; if a value other than the default value is agreed upon, it will be recorded in the Connection Agreement (ATO);

- i. A notice of a change of setpoint of k will be given two weeks in advance by the RSO;
- j. The additional reactive current injection may be ended either when the voltage deviation returns from a value of more than 10% to a value of less than 10% of the effective nominal value on the terminals of the individual generation units of the power park module or after a period of time of five seconds after the start of the fault; a repeated activation of the dynamic grid support after it has been ended must be conceptually avoided;
- k. The reactive current injection at maximum voltage drop is at least I_N ; a higher value than I_N is not required;
- l. The tolerance for the magnitude of the reactive current injection at a voltage drop is determined by lines above and below the characteristic that describes the magnitude of the additional reactive current injection as a function of the voltage change [see figure 4.25 for an example], with parameters:
 - 1°. the upper limit for the tolerance is determined by a line with a slope of constant k equal to the set value and with a 10% increase with respect to the line through the axes origin with the same slope;
 - 2°. the lower limit for the tolerance is determined by a line with a slope of constant k equal to the set value and with a 20% decrease with respect to the line through the axes origin with the same slope;
- m. For voltages below 15% U_C , no current supply is required.

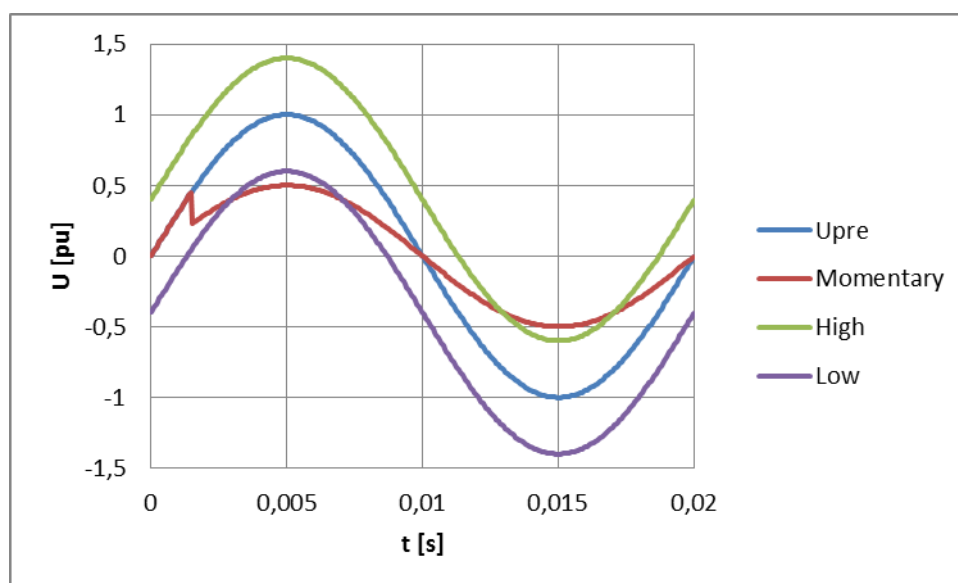

Figure 4.23 Example of detection of a sudden change in the instantaneous sinusoidal voltage (Momentary) in comparison of the pre-fault sinusoidal voltage (Upre) and the high and low 5% boundaries

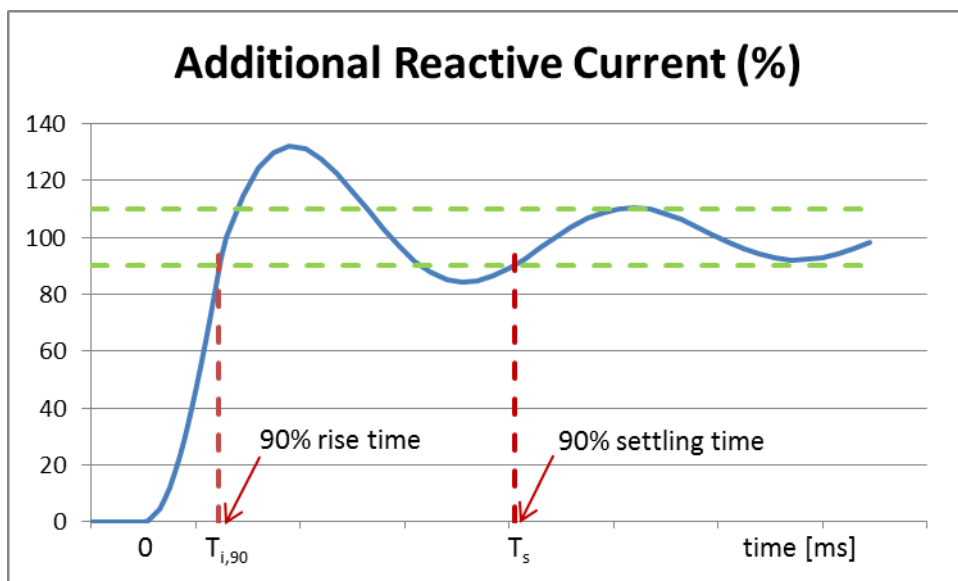

Figure 24 Additional reactive current step response

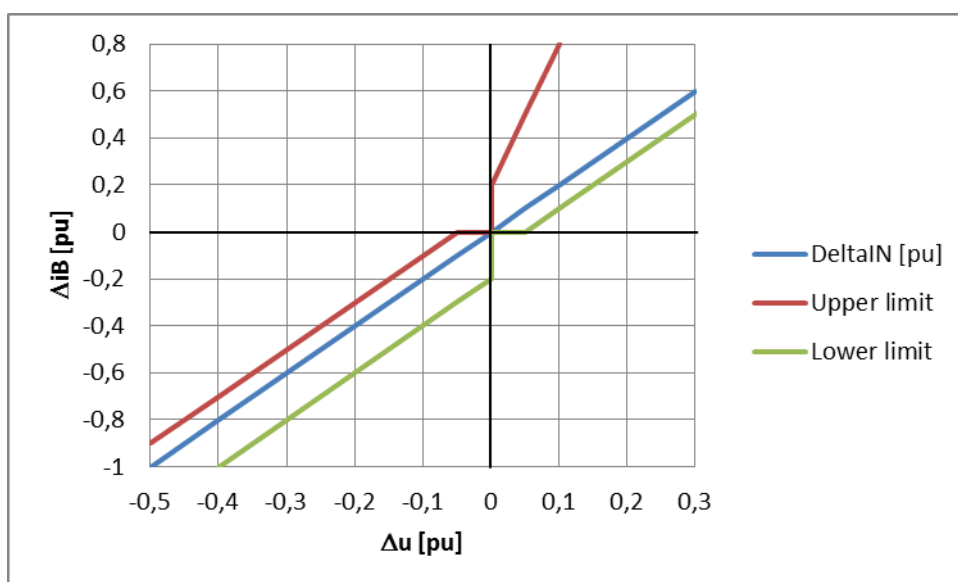

Figure 25 Additional reactive current injection; example for $k=2$ and tolerances

Netcode elektriciteit Article 3.19, sub 12 and accordingly applied to in Article 3.33, sub 5:
 If agreed in consultation between the RSO and the TSO, the requirement for the supply of fast fault current by a PPM in the event of symmetrical faults shall be laid down in the connection and transmission agreement.

Netcode elektriciteit Article 3.19, sub 11 and accordingly applied to in Article 3.33, sub 5:
 The PPM is capable of fast reactive current injection in case of asymmetrical faults as follows:

- a. The requirements as formulated in paragraph 10 of this article [3.19] apply accordingly

to the positive sequence and negative sequence components of the voltage and to the positive sequence and negative sequence components of the additional reactive current injection;

- b. The adjustment range of k_2 for the negative sequence component of the additional reactive current injection is: $2 \leq k_2 \leq 6$;
- c. The adjustment step for k_2 shall be less than or equal to 0.5;
- d. The default value of k_2 is equal to k ;
- e. For generating units based on a doubly-fed induction machine, a specific setting of k_2 is not required;
- f. For the negative sequence component of the voltage change, the additional negative sequence component of the current injection is only required if the negative sequence component of the voltage is large enough for a reliable phase angle detection;
- g. If the maximum value of the reactive current is reached, the contribution of the positive sequence and negative sequence components of the additional reactive current injection shall be in proportion to the settings of k and k_2 ;
- h. The tolerance for the magnitude of the negative component of the reactive current injection at a negative component of the voltage increment is determined by lines above and below the characteristic that describes the magnitude of the additional reactive current injection as a function of the voltage change [see figure 4.25 for an example], with parameters:
 - 1°. the upper limit for the tolerance is determined by a line with a slope of constant k_2 equal to 6 and with a 20% increase with respect to the line through the axes origin with the same slope;
 - 2°. the lower limit for the tolerance is determined by a line with a slope of constant k_2 equal to the set value and with a 10% decrease with respect to the line through the axes origin with the same slope.

Objective

The objective is to prove the (offshore) Power Park Module's capability to provide fast fault current injection in accordance with the conditions set out in point (b) of Article 20(2). The test and simulation shall be deemed successful if compliance with the requirement laid down in point (b) of Article 20(2) is demonstrated.

Fast fault current injection Tests for a PPM and OPDM Generating Unit

Objective

- To prove the PPM Generating Unit's capability to provide fast fault current injection in accordance with the conditions set out in point (b) of RfG Article 20(2) and to Netcode elektriciteit article 3.19, sub 10 and 12 and article 3.33, sub 5;
- To validate the PPM Generating Unit and FACTS models.

The tests shall be performed as a type test, either by an independent test institute or by the manufacturer. If the type tests are performed by the manufacturer, they need to be witnessed and approved by an independent test institute. The type tests may be executed together with the FRT test for a PPM and OPPM Generating Unit.

Tests shall be executed as a type test according to FGW TG3-2018 Rv. 25. In deviation from FGW TG3-2018 Rv. 25 the tests shall be executed for the following minimum fault scenarios:

- Type B/C: fault residual voltage 5% of rated voltage, fault duration 200 ms;
- Type D: fault residual voltage lower than 5% of rated voltage, fault duration 250 ms;
- Type B/C: fault voltage between 40% and 50% of rated voltage, fault duration 1200 ms;
- Type D: fault voltage between 40% and 50% of rated voltage, fault duration 1800 ms;
- Type B/C: fault voltage between 70% and 80% of rated voltage, fault duration 1900 ms.
- Type D: fault voltage between 70% and 80% of rated voltage, fault duration 2800 ms.

The fault voltage corresponds to the FRT-profile on the connection point. For the test on generating unit level, a correction for transformer and cables is allowed.

The active and reactive power, the fault types (symmetrical and asymmetrical) and the k-factor shall be set according to FGW TG3-2018 Rv. 25.

Fast fault current injection Simulations

Objective

- To prove the PPM Generating Unit's capability to provide fast fault current injection in accordance with the conditions set out in point (b) of RfG Article 20(2) and to Netcode elektriciteit article 3.19, sub 10 and 11;
- To validate the PPM Generating Unit and FACTS models.

In case of a PPM type B a number of simplifications may be applied. Regarding fault-ride-through and fast fault current injection, generating units are type tested on these requirements. If for these requirements unit certificates are available for all generating units in the PPM, simulations to prove compliance with these requirements will not be required by the RSO.

Simulation procedure

Simulations shall be executed as part of the fault-ride-through simulations, as described in the paragraph on fault-ride-through.

- Three-phase and asymmetrical (1- and 2-phase) faults will be simulated;
- Simulation of voltage dips as described in the paragraph on fault-ride-through at Connection Point;
- Simulation of a voltage dip at the Connection Point of such a value that all generating units in the PPM experience a voltage drop slightly higher than 5% so that all generating units in the PPM activate the fast fault current injection, followed by restoration of the voltage to a nominal value within a period of time of five seconds after the start of the dip;
- Simulation of the symmetrical 3-phase voltage at the Connection Point slowly ramp wise dropping to such a level that all generating units in the PPM activate the fast fault current injection;
- The simulations will be executed for a reactive power output Q/P_{\max} of 0%, for the maximum reactive power output and for the maximum reactive power input;
- For Power Park Module Generating Units the k-factor shall be set to the default value of 5 (if another value will be used in actual operation the k-factor for the simulations can be defined in consultation with the RSO); based on the simulation results (additional reactive current, voltage dip) the k-factor at the Connection Point shall be calculated for a three-phase fault according to the definition and equation given in Netcode elektricitet article 3.19 sub 10 and 11 and article 3.33, sub 5.

Documentation / calculated parameters

- At the Connection Point: power (P, Q), Voltage (V), Current (I) as function of time;
- At the PPM Generating Unit terminals: power (P, Q), Voltage (V), Current (I) as function of time;
- Tap changer positions of transformers;
- Switching on/off position of reactive power compensation equipment if applicable;
- Check calculated parameters with protection settings (voltage, current, power) at the Generating Unit, MV grid and HV connection;
- Applied parameter settings of generating unit and park controller models;
- Based on the simulation results (additional reactive current, voltage dip) the k-factor at the Connection Point shall be calculated for all simulated three-phase and asymmetrical (1- and 2-phase) faults according to the definition and equation given in Netcode elektricitet Article 3.19, sub 10 and 11 and Article 3.33, sub 5.

Simulation evaluation criteria

The test simulation be deemed successful if the following conditions are fulfilled:

- The PPM is capable to fault-ride-through according to the requirements;
- The PPM model has been validated on GU level;
- For faults with residual voltage > 0.15 pu at the generating unit terminals:
 - Reactive current injection and k-factor according to controller setting;

- the 90% rise time is not larger than 30 to 50 ms, including a maximum of 20 ms needed for sequence calculations;
- the settling time is not larger than 60 to 80 ms, including a maximum of 20 ms needed for sequence calculations.

4.2.19 Synthetic inertia (If applicable)

Applicable to:

	PPM	OPPM			Type C	Type D
--	-----	------	--	--	--------	--------

RfG article: 21(2)(a)

Netcode elektriciteit article: none

Test: none

Simulation: RfG article 55(5) (PPM, OPPM)

Requirement to be verified (if applicable)

RfG Article 21: Requirements for type C Power Park Modules

2. Type C Power Park Modules shall fulfil the following additional requirements in relation to frequency stability:
 - (a) the relevant TSO shall have the right to specify that Power Park Modules be capable of providing synthetic inertia during very fast frequency deviations;
 - (b) the operating principle of control systems installed to provide synthetic inertia and the associated performance parameters shall be specified by the relevant TSO.

Netcode elektriciteit Article 3.13:

2. The PGM is capable of staying connected to the network at a rate of change of frequency of 1 Hz/s for SPGM and 2 Hz/s for PPM in a 500 ms time period.

Netcode elektriciteit:

For the time being the synthetic inertia is not required.

Based on the Dynamic Stability Assessment findings, each TSO choosing to apply SI shall define at least the following requirements for the relevant elements:

- Frequency or df/dt measurement criteria:
 - time window (speed)
 - accuracy, and
 - total delay time
- Function characteristics (e.g. df/dt vs. Δf , deadband and droop)
- TSO input signal for activation and access to alter settings such as droop.

The above considerations require a well-founded strategy to deal with technical and operational limit of SI exploitation.

Objective

To demonstrate the Power Park Module's capability of providing synthetic inertia to a low frequency event as set out in point (a) of Article 21(2).

Synthetic inertia Simulations

Simulation procedure

This simulation focusses on PPM's synthetic inertia controller to supply instant, short-time additional active power with falling network frequency.

- The simulations shall be carried out by transient stability model calculations at changes in network frequency;
- A transient model of the PPM controls shall be used;
- The Network shall be presented as an equivalent with variable frequency and minimum short circuit impedance;
- Simulations shall be performed with:
 - the synthetic inertia controller active and not active;
 - zero, maximum reactive power import and maximum reactive power export;
 - active power 60%, 80% and 100% of maximum capacity;
 - frequency drop from 50.0 Hz to 49.0 Hz with gradient of 0.5 Hz/s.

Documentation / calculated parameters

Graphs from the transient stability simulations shall be recorded for evaluation:

- Active and reactive power at the Connection Point;
- Active and reactive power at the generator terminals;
- Excitation voltage and current;
- Rotor angle and rotor speed (if applicable);
- Network frequency;
- Voltage and current at the generator terminals (rms)
- Activation of limiters and electrical protections.

Simulation evaluation criteria

The simulation shall be deemed successful if the model demonstrates that it provides synthetic inertia according to the performance parameters that are specified by the relevant TSO.

4.2.20 Power Quality

Applicable to:

	PPM	OPPM				Type D
--	-----	------	--	--	--	--------

RfG article: none

Netcode elektriciteit article: 2.14, 2.15, 2.28, 2.40

Test: required by RSO; not according to RfG

Simulation: required by RSO; not according to RfG

Requirement to be verified

From Netcode elektriciteit, article 2.14:

1. Without prejudice to the provisions in or pursuant to this code, all equipment and appliances in or connected to the electrical installations shall comply with the standards applicable to these operating assets and equipment.
2. The machines, appliances, materials and parts included in an electrical installation comply with the legal requirements established for the trade or use thereof.
3. The electrical installation is resistant to the short-circuit power expected by the grid operator on site.

From Netcode elektriciteit, article 2.15:

1. Electrical installations and connected devices do not cause inadmissible interference/disturbances via the RSO's network.
2. The RSO may request the connected party to make provisions such that the inadmissible nuisance ceases or, for a number of hours determined by the RSO, prohibit the connected party from using equipment and engines to be designated by the RSO.
3. Notwithstanding the second paragraph, the TSO shall apply central filtering if the responsibility for taking the measures cannot be unambiguously assigned to the connected party or to the TSO, provided that the unacceptable nuisance is caused by voltage phenomena as a result of the interaction of an ac cable longer than 5 km, part of the connection, or installation of the connected party and the local grid configuration

From Netcode elektriciteit, article 2.28:

1. The connected party demonstrates that in the case of machines, devices, materials and components in electrical installations or connected to electrical installations whose electromagnetic compatibility is not laid down in a legal regulation, at the network connection point the requirements for electromagnetic compatibility, imposed by the network operator, are met.
2. For equipment with a capacity greater than 11 kVA, the "Richtlijnen voor toelaatbare harmonische stromen geproduceerd door apparatuur met een vermogen groter dan 11 kVA" of June 1997 issued by EnergieNed apply.

From Netcode elektriciteit Article 2.40:

1. In addition to Article 2.14, paragraph 2, the electrical installation and the machines, appliances, materials and parts included therein comply with NPR-IEC/TR 61000-3-7:2008 en (Electromagnetic compatibility – Part 3-7: Limits – Assessment of emission limits for the connection of fluctuating installations to MV, HV and EHV power systems).
2. In the case of a connection to a high voltage network [a grid with a voltage level higher than 35 kV], the connected party shall demonstrate by calculation that his electrical installation complies with the first paragraph.
3. In the case of a connection to a medium voltage network [a grid with a voltage level higher than 1 kV and lower than or equal to 35 kV], where the power to be connected at the connection point exceeds the values listed in table 3 of the NPR-IEC/TR 61000-3-7:2008 en, the connected party shall show by means of calculation that his electrical installation complies with the first paragraph.
4. If one of the paragraphs two or three of this article applies, the manner of application of the NPR-IEC/TR 61000-3-7:2008 en is laid down in an implementation instruction and is added as an appendix to the connection agreement (ATO).
5. In addition to article 2.28, the “Richtlijn voor harmonische stromen en netspanningsasymmetrie bij éénfasige 25 kV-voedingen” from March 1999, issued by EnergieNed, applies to the connection of single-phase traction power supplies to high-voltage networks.

The power quality measurements and simulations are subdivided into three topics, to be described in the next following paragraphs:

- Rapid voltage change;
- Flicker;
- Harmonics.

Power quality measurements are divided in two topics:

- Power quality conformity test measurements of the equipment;
- Power quality measurements at the connection point.

Power quality measurements at the connection point are executed during energisation, construction, and full operation, to be described in the first following paragraph: "Power quality measurements at connection point".

Power quality conformity test measurements of equipment are, amongst others:

- conformity test:
 - type test;
 - routine test;
- acceptance test;
- commissioning test;
- other tests.

The Power quality conformity test measurements of equipment are used as input to the simulations. Power quality measurements at the connection point are used as validation measurements of the power quality simulations and are performed during energisation, construction, and full operation, to be described in the next paragraph.

Power Quality measurements at connection point

Objective

The connected party shall demonstrate that machines, devices, materials and parts in electrical installations or connected to electrical installations, where the electromagnetic compatibility is not determined in a rule enforced by law, at the Connection Point, specifications of the grid operator are satisfied regarding electromagnetic compatibility.

Procedure

At least the initial and final power quality measurements shall be performed containing the worst case emissions of the installation:

- Initial power quality measurement:
 - The weekly based power quality measurement shall be performed during at least one week starting with first energization. This shall cover first energization of the step-up transformer and cables of the collection grid of the PPM.
- Interim power quality measurement:
 - In case an interim power quality measurement is required during the building phase this measurement shall be performed according to the procedure for the final power quality measurement if not agreed otherwise.
- final power quality measurement:
 - The weekly based voltage quality measurement shall be performed during the period between EON and FON containing the worst case emissions transferring from minimum, to none, to full operation of the PPM.
 - This measurement has to include the switching operation of wind turbines, cables, transformer and reactive power compensation equipment. These switching operations should preferably be performed manually initiated.
 - During EON and FON measurement data of the power quality monitoring system of TenneT can be used for this purpose. This measurement data will be delivered on request. This power quality monitoring measurement system of TenneT is a continuously measured power quality measurement according to IEC 61000-4-30 class A.

Documentation / Measurements:

The measurements shall be taken at the Connection Point, given the measurement quality of the netcode.

- The following power quality aspects will be measured with a class 'A' of NEN-EN-IEC 61000-4-30 measurement device:
 - slow voltage variations ('langzame spanningsvariates')
 - fast voltage variations ('snelle spanningsvariates') including
 - flicker: P_{LT} , P_{ST} ;
 - voltage dips;
 - rapid voltage change due to inrush phenomena;
 - asymmetry ('asymmetrie');
 - THD, harmonic and interharmonic voltages ('harmonische');
- During the measurement of the harmonic voltages, the harmonic interharmonic, in time correlation with the power quality aspects;
- Dates and times will be provided of planned and actual switching times of the equipment in the PPM. These dates and switching times are needed to clarify the measurements and shall be delivered in comma separated file or excel-file;
- A report shall analyse the measurements and point out the switching events;
- The voltage quality aspects measurements shall be delivered in comma separated file or excel-file.

Evaluation Criteria:

Evaluation will be performed based on national legislation, standards, rules and best practices:

- Netcode elektriciteit;
- 'Richtlijnen voor toelaatbare – harmonische stromen geproduceerd door apparatuur met een vermogen groter dan 11 kVA' d.d. Januari 1996 published by EnergieNed (to check harmonics generated according NEN-EN-IEC 61400-21-1 type test measurements);
- Nederlandse praktijkrichtlijn NPR-IEC/TR 61000-3-6 (en) Electromagnetic compatibility (EMC) – Part 3-6: Limits – Assessment of emission limits for the connection of distorting installations to MV, HV and EHV power systems;
- Nederlandse praktijkrichtlijn NPR-IEC/TR 61000-3-7 (en) Electromagnetic compatibility (EMC) – Part 3-7: Limits – Assessment of emission limits for the connection of fluctuating installations to MV, HV and EHV power systems;
- NEN-EN-IEC 61400-21-1, (en) Wind energy generation systems – Part 21: Measurement and assessment of power quality characteristics of grid connected wind turbines;
- NEN-EN-IEC 61000-4-30, (en) Electromagnetic compatibility (EMC) – Part 4-30: Testing and measurement techniques – Power quality measurement methods.

4.2.20.1 Rapid voltage change

Objective

The connected party shall demonstrate its capability to limit rapid voltage change in the HV and EHV power system. The emitted single rapid voltage change of the PPM shall be less than the single rapid voltage change limits given in this paragraph.

Implementation

Concerning fluctuating voltages on the Connection Point, the following limits are specified in the Netcode elektriciteit for steady-state voltage change (ΔU_{ss}) and for maximum voltage change (ΔU_{max}) as specified in Netcode elektriciteit article 7.3, paragraph 3(b).

The terms are defined in NEN-EN-IEC 61000-4-30: Electromagnetic compatibility (EMC) – Part 4-30: Testing and measurement techniques – Power quality measurement methods.

In order to be able to maintain the power quality levels, the RSO requests the connected party in accordance with Netcode elektriciteit article 2.40, paragraph 4, to:

- Limit the emissions to HV and EHV power systems to the values as given by NPR-IEC/TR 61000-3-7: Electromagnetic compatibility (EMC) – Part 3-7: Limits – Assessment of emission limits for the connection of fluctuating installations to MV, HV and EHV power systems;
- Limit the rapid voltage change in accordance with the table below for networks with a system voltage U_n of: $66 \text{ kV} \leq U_n \leq 380 \text{ kV}$ (during normal operating conditions defined by the Netcode)

Number of accepted changes [n]	$\Delta U_{max} / U_n$ [%]	$\Delta U_{ss} / U_n$ [%]
$n \leq 4$ per day	5	3
$n \leq 2$ per hour and > 4 per day	3	3
$2 < n \leq 10$ per hour	2,5	2,5

The permissible voltage change $\Delta U_{max} / U_n$ (%) and number of changes in a given period should be applied in such a way that the number of changes of magnitude $\Delta U_{max} / U_n$ does not exceed the number specified within the total time period corresponding to the rate: e.g. no more than 4 changes of 5% are permitted during any one 24 hour period.

Measurements

The rapid voltage change simulation will be supported by power quality measurements at the connection point that shall be started directly after the first energisation, will continue during the constructing phase and shall be performed during one week with full operation of the PPM. Details of the test procedure are given in the paragraph on Power Quality measurements. A report of the measurements shall be delivered.

Simulation procedure

- An engineering assessment is required to demonstrate the capability of the PPM

- This assessment has to include rms simulations of switching operations of: transformers (step-up and other), cables, generating units and reactive power compensation equipment
- Starting points of these simulation shall be:
 - Minimum short circuit power of the transmission system;
 - X/R ratio of the transmission system at the Connection Point that causes the worst case ΔU_{\max} .

Documentation/calculated parameters

- A report of the simulation shall be delivered;
- At the Connection Point the following parameters should be listed in the report:
 - $U_{\text{rms}(1/2)}$, ΔU_{\max} , and ΔU_{ss} as defined by the Nederlandse norm NEN-EN-IEC 61000-4-30:2015 or latest version;
 - $U_{\text{rms}(1/2)}$, ΔU_{\max} , and ΔU_{ss} are based on phase-to-phase voltages;
 - U: individual phase-to-phase voltages based on $U_{\text{rms}(1/2)}$;
 - $U_{\text{rms}(1/2)}$ voltage shape, U(t)
 - the time function of $U_{\text{rms}(1/2)}$ (see figure 4.26);
 - voltage change characteristic, $\Delta U(t)$
 - The time function of the $U_{\text{rms}(1/2)}$ voltage change (see figure 4.26); since this characteristic is only used for assessments using calculations, the voltage in the steady-state condition is assumed to be constant within the measurement accuracy;
 - report maximum voltage change characteristic, ΔU_{\max} (kV);
 - report steady-state voltage change, ΔU_{ss} ;
 - report $\Delta U_{\max}/U_n$ (%) according the evaluation criteria;
 - report number of changes (per day) or (per hour) according the evaluation criteria;
- List the sequence of events that causes the rapid voltage change;
- Apart from the voltages also the currents at the Connection Point shall be simulated, in time correlation with the voltage quality aspects;
- Single rapid voltage change dependent electro technical parameters of the components of the PPM; not limited to the components:
 - step-up transformer: remnant magnetism, hysteresis curves;
 - other transformers in the PPM: remnant magnetism, hysteresis curves, sympathetic effects;
 - cabling and lengths;
 - filters;
 - reactive power compensation;
 - harmonic impedance of Generating Units and other solid state components;
 - harmonic voltage and current injection source of the Generating Units and other solid state components;
 - conformity test, type test and routine test of single rapid voltage change parameters of the Generating Units or other solid state components.

Rapid Voltage Change State	Description	$\Delta U_{\max}/U_n$ (%)	Compliance with $\Delta U_{\max}/U_n$	$\Delta U_{ss}/U_n$ (%)	Compliance with $\Delta U_{ss}/U_n$
1			Yes / No		Yes / No
2			Yes / No		Yes / No
3			Yes / No		Yes / No
4			Yes / No		Yes / No
5			Yes / No		Yes / No
...		

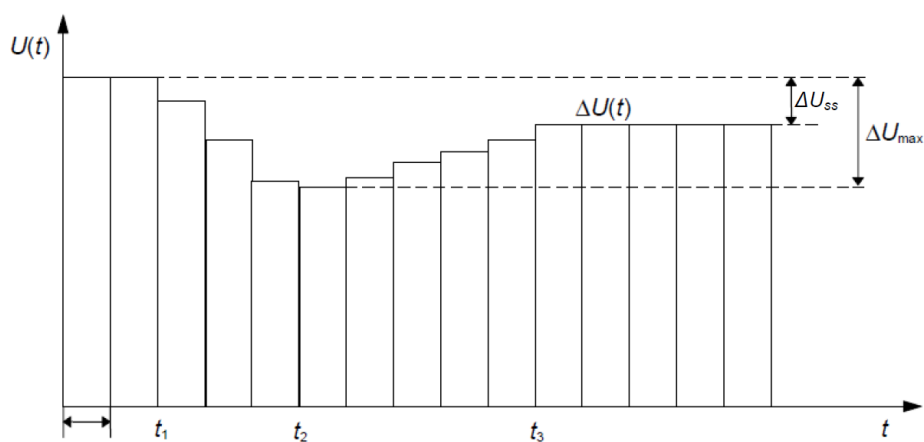

Figure 4.26 Histogram evaluation of $U(t)$

Evaluation criteria

Evaluation will be performed based on national legislation, standards, rules and best practices:

- Netcode elektriciteit;
- Nederlandse praktijkrichtlijn NPR-IEC/TR 61000-3-7 (en) Electromagnetic compatibility (EMC) – Part 3-7: Limits – Assessment of emission limits for the connection of fluctuating installations to MV, HV and EHV power systems;
- The rapid voltage change should be less or in accordance with the table below for grids given a system voltage U_n of: $66 \text{ kV} \leq U_n \leq 400 \text{ kV}$; during normal operating conditions defined by the Netcode elektriciteit. The next table is constructed based on the Netcode elektriciteit and NPR-IEC/TR 61000-3-7.

Levels for rapid voltage changes as a function of the number of such changes in a given period for grid given a system voltage U_n of: $66 \text{ kV} \leq U_n \leq 400 \text{ kV}$

Number of accepted changes [n]	$\Delta U_{\max} / U_n$ [%]	$\Delta U_{ss} / U_n$ [%]
$n \leq 4$ per day	5	3
$n \leq 2$ per hour and $n > 4$ per day	3	3
$2 < n \leq 10$ per hour	2,5	2,5

The permitted voltage change $\Delta U_{\max} / U_n$ and number of changes in a given period should be applied so that the number of changes of magnitude $\Delta U_{\max} / U_n$ does not exceed the number specified within the total time period corresponding to the rate: e.g. no more than 4 changes of 5% are permitted during any one 24 hour period. U_n is one of the system voltages: 66 kV, 110 kV, 150 kV, 220 kV, and 380 kV.

4.2.20.2 Flicker emission

Objective

The flicker emission level of the PPM be less than the Flicker emission limit P_{ST} and P_{LT} in the HV and EHV power system.

Implementation

Connected party emission limits: $E_{P_{STi}} = 0,35$ and $E_{P_{Lti}} = 0,25$.

The terms are defined in IEC 61000-3-7.

Measurements at connection point

The flicker emission simulation shall be supported by power quality and voltage quality measurements that shall be started directly after the first energisation, will continue during the constructing phase up to the FON, and shall be performed on a weekly base. The measurements shall contain the worst case flicker emissions transferring from minimum, to none, to full operation of the PPM. Details of the test procedure are given in the paragraph on Power Quality measurements.

Simulation procedure

Flicker P_{ST} and P_{LT} shall be determined at the Connection Point. This should be done at least according to procedure described in NEN-EN-IEC 61400-21-1: 2019 or latest version.

Documentation / calculated parameters:

The connected party shall deliver a report with calculated emission levels of the flicker at the Connection Point of the PPM:

- Emitted P_{ST} , P_{LT} at point of connection of the PPM;
- Applied Short circuit power and X/R ratio;
- Applied wind turbine characteristics such as flicker coefficient;
- Measurements results according to: NEN-EN-IEC 61400-21-1:2019 Wind energy generation systems – Part 21-1: Measurement and assessment of electrical characteristics – Wind turbines, paragraph 8.2: Power quality aspects
- Flicker dependent electro technical parameters of the components of the PPM; not limited to the components:

- step-up transformer;
- other transformers in the PPM;
- cabling and lengths;
- filters;
- reactive power compensation;
- harmonic impedance of Generating Units and other solid state components;
- harmonic voltage and current injection source of the Generating Units and other solid state components;
- conformity test, type test, and routine test of flicker parameters parameters of the Generating Units or other solid state components; the test measurement standards are described in the evaluation criteria.

Table Short-term (P_{sti}) and long-term (P_{lti}) flicker

Flicker State	Description	P_{sti}	E_{Psti}	Compliance with $P_{sti} \leq E_{Psti}$	P_{lti}	E_{Plti}	Compliance with $P_{lti} \leq E_{Plti}$
1				Yes / No			Yes / No
2				Yes / No			Yes / No
3				Yes / No			Yes / No
4				Yes / No			Yes / No
5				Yes / No			Yes / No
...			

Evaluation Criteria:

- Evaluation will be performed based on national legislation, standards, rules and best practices:
- Netcode elektriciteit;
- Nederlandse praktijkrichtlijn NPR-IEC/TR 61000-3-7 (en) Electromagnetic compatibility (EMC) – Part 3-7: Limits – Assessment of emission limits for the connection of fluctuating installations to MV, HV and EHV power systems;
- The Emission levels shall be lower than the emission limits: $E_{Psti} = 0,35$ and $E_{Plti} = 0,25$;
- Measurements results according to: NEN-EN-IEC 61400-21-1:2019 Wind energy generation systems – Part 21-1: Measurement and assessment of electrical characteristics – Wind turbines, paragraph 8.2: Power quality aspects (or later version).

4.2.20.3 Harmonics

Objective

The Connected Party shall demonstrate the capability of the PGM to limit the emission of harmonic, inter harmonic, sub harmonics and THD voltages in the HV and EHV power

system. The Connected Party shall demonstrate that the emission level at the Connection Point due to the current injection and voltage altering devices of various sources in de distorting installation in combination with the transmission system and the distorting installation is lower than the emission limit.

Implementation

The Connected Party is responsible for the emission level U_{hi} originating from the harmonic contribution V_{INC} of the Park Power Module (PPM). The PPM is a distorting installation (NPR-IEC/TR 61000-3-6). The emission level U_{hi} of the PPM shall be below the emission limit E_{uhi} of the PPM:

$$U_{hi} = V_{INC} \quad \text{and} \\ |U_{hi}| \leq E_{uhi}.$$

The emission limit E_{uhi} is specified by the transmission system operator. The PPM shall demonstrate that, in combination with the transmission system and other components of the PPM, its emission level $|U_{hi}|$ at the Connection Point due to the distorting current injection, due to the distorting voltage injection and due to the voltage altering components in the PPM is lower than its emission limit E_{uhi} .

Measurements

The harmonics simulation will be supported by power quality measurements at the connection point and of the equipment. The measurements at the connection point shall be conducted and made possible by the Connected Party. The measurements are performed on a weekly basis. Measurement data of the TenneT power quality monitoring can be delivered to the connected party on request. The measurements shall start directly after the first energisation, shall continue during the constructing phase up to the final operation notification. A week with the worst case harmonic emission shall be chosen given a production that transfers from minimum, to none, to full operation of the PPM. Details of the test procedure are given in the paragraph on Power Quality measurements.

Measurement test results of the equipment shall be delivered according to:

- NEN-EN-IEC 61400-21-1:2019 Wind energy generation systems – Part 21-1: Measurement and assessment of electrical characteristics – Wind turbines, paragraph 8.2: Power quality aspects (or later version);
- NPR-IEC/TR 61400-21-3:2019 (en) Wind energy generation systems - Part 21-3: Measurement and assessment of electrical characteristics - Wind turbine harmonic model and its application (or later version).

Simulation procedure

- The connected party shall simulate the harmonic, inter harmonic and subharmonic emission level from the PPM for all operating states of the PPM and connected to the transmission system, for instance the PPM-operating states during:

commissioning of the PPM, normal operation PPM and operation with PPM-components out of order or reordered PPM-cabling, etc.

- Starting point of the simulation shall be:
 - A description of the worst case emission level of the PPM taking into account the PPM-operating states, for instance: commissioning, maintenance and disturbance;
 - An active power output of zero, 10% up to and including 100 % of P_{\max} in steps of 10%;
 - A reactive power output of: Q_{\max} consumption, Q_{\max} production and zero Mvar at the Connection Point;
 - Harmonic impedance (loci, envelope) of the transmission system at the Connection Point: $Z_{\text{Transmission system}}$;
 - The frequency dependent performance of the harmonic distorting installation PPM;
 - Magnitude and phase statistically correct harmonic simulations based on reliable test measurement results of the equipment.

Documentation / calculated parameters

The connected party shall deliver a report with calculated emission levels of the harmonic, inter harmonic, sub harmonic and THD voltages at the Connection Point of the PPM.

- The report shall include a table with the following calculation results for all calculated emission levels: Maximum amplification factor k at the point of connection per harmonic order, calculated as:

$$k = \left| \frac{Z_{\text{combination of transmission system and distorting installation}}}{Z_{\text{transmission system}}} \right|$$

or:

$$k = \left| \frac{Z_{\text{distorting installation}}}{Z_{\text{transmission system}} + Z_{\text{distorting installation}}} \right|$$

- The report shall include maximum harmonic emission level $|U_{hi}| = |V_{INC}|$ per harmonic order, interharmonic order and subharmonic order at the evaluation point of the PPM caused by the harmonic contribution from the equipment in the PPM connected to the transmission system, neglecting the background harmonic voltage distortion of the transmission system;
- The report shall include a compliance assessment of the emission level against the allocated emission limits given by the system operator; the connected party shall deliver tables as given in the format displayed in the next four tables;
- The report shall include frequency-dependent electrical parameters of the components of the PPM; not limited to the components:
 - step up transformer;
 - underground cables and overhead lines with, distributed parameters and lengths;

- filters, e.g. active or passive filters;
- reactive power compensation;
- harmonic impedance of the Generating Unit and other solid state components;
- harmonic voltage, and current injection source of the Generating Unit and other solid state components;
- conformity test, type test and routine test of frequency dependent parameters of the Generating Unit and of other solid state components; the test measurement standards are described in the evaluation criteria.

Table: amplification factor

Harmonic order h	Identification Operational state of the PPM, resulting in highest k	PPM Resistance at Connection Point of the distorting installation (PPM) (Ω)	PPM Reactance at Connection Point of the distorting installation (PPM) (Ω)	Transmission system Resistance at Connection Point of the distorting installation (PPM) (Ω)	Transmission system Reactance at Connection Point of the distorting installation (PPM) (Ω)	Maximum amplification factor k at Connection Point of the PPM (pu)
...						
...						

Table: harmonics

harmonic order h	Identification Operational state of the PPM, resulting in highest $ U_{hi} = V_{inc} $	$ U_{hi} = V_{inc} $ (%)	PPM emission limit E_{uhi} (%)	Compliance with Emission limit PPM	$ V_{inc} /E_{uhi}$ (pu)
...				Yes / No	
...				Yes / No	

Table: THD

Harmonic	Emission Level $ U_h $	Emission Limit E_{hi}	Compliance with Emission Limit
THD (h=2 up to and including 40)			Yes / No
...			Yes / No

Table: interharmonics and sub harmonics

Harmonic	Emission Level $ U_{hi} $	Emission Limit E_{hi}	Compliance with Emission Limit
Sub harmonic			Yes / No
Inter harmonic			Yes / No

Evaluation Criteria

Evaluation will be performed based on national legislation, standards, rules and best practices:

- Netcode elektriciteit;
- Nederlandse praktijkrichtlijn NPR-IEC/TR 61000-3-6: 2008 (en) Electromagnetic compatibility (EMC) – Part 3-6: Limits – Assessment of emission limits for the connection of distorting installations to MV, HV and EHV power systems (or later version);
- Measurement results shall be delivered according to NEN-EN-IEC 61400-21-1: 2019 (en) Wind energy generation systems – Part 21-1: Measurement and assessment of electrical characteristics – Wind turbines, paragraph 8.2: Power quality aspects (or later version);
- NPR-IEC/TR 61400-21-3:2019 (en) Wind energy generation systems - Measurement and assessment of electrical characteristics - Wind turbine harmonic model and its application (or later version);
- NEN-EN-IEC 61000-4-30 EMC: Testing and measurement techniques – Power quality measurement methods;
- Given harmonic, inter, sub, and THD harmonic limits by the relevant system operator: harmonic emission within emission limits specified by RSO.

4.2.21 Insulation coordination

Applicable to:

SPGM	PPM	OPPM				Type D
------	-----	------	--	--	--	--------

RfG article: none

Netcode elektriciteit article: 2.13

Test: none

Simulation: required by RSO; not according to RfG

Requirement to be verified

Netcode elektriciteit article: 2.13, sub 3:

The RSO informs the connected party and consults with him as far as applicable at the first connection and in the event of later changes to the grid regarding insulation coordination.

Objective

The connected party shall demonstrate its capability to limit the transient and temporary overvoltage emissions to the HV and EHV power system and the connected party shall comply with the insulation coordination of the transmission system operator.

Procedure

Calculations of transient and temporary overvoltage due to events, given:

- Netcode elektriciteit article: 2.13, paragraph 3: (d) insulation coordination;
- NEN-EN-IEC 60071-1 Insulation co-ordination – Part 1: Definitions, principles and rules;

- IEC 60071-2 Insulation co-ordination – Part 2: Application guide;
- Praktijkrichtlijn NPR-IEC/TR 60071-4 Insulation co-ordination – Part 4: Computational guide to insulation coordination and modelling of electrical networks.

Documentation / calculated parameters

The connected party shall deliver a report with:

- documentation that demonstrates the compliance with the Netcode elektriciteit article: 2.13, sub 3: (d) insulation coordination;
- if the PPM exceeds the basic thought of Netcode elektriciteit article: 2.13, sub 3: (d) insulation coordination, a list of more events and the motivation of:
 - calculated events;
 - non calculated events;
 - types of transient and temporary overvoltage generated;
 - non calculated types of transient and temporary overvoltage generated;
- time function graphs of emitted transient and temporary overvoltages at the PPM Connection Point;
- calculated rate-of-rise values: du/dt and di/dt ;
- tables correlating emitted transient and temporary overvoltages and rate-of-rise values at the PPM Connection Point to overvoltage withstand values of various electrical installation components;
- transient-dependent electrical parameters of the components of the PPM; not limited to the components:
 - step up transformer;
 - underground cables and overhead lines with, distributed parameters and lengths;
 - filters, e.g. active or passive filters;
 - reactive power compensation;
 - transient impedance of the Generating Units and other solid state components.

Evaluation Criteria

- Evaluation will be performed based on national legislation, standards, rules and best practices;
- Netcode elektriciteit article: 2.13, sub 3: (d) insulation coordination;
- The connected party shall indemnify and hold the transmission system operator harmless against and from any claim alleging an infringement of the insulation coordination; the transmission system operator is entitled to reject the connection of the connected party due to overvoltages that are not covered by the insulation coordination;
- NEN-EN-IEC 60071-1 Insulation co-ordination – Part 1: Definitions, principles and rules;
- IEC 60071-2 Insulation co-ordination – Part 2: Application guide;
- Praktijkrichtlijn NPR-IEC/TR 60071-4 Insulation co-ordination – Part 4:

- Computational guide to insulation coordination and modelling of electrical networks;
- Consider events of: insulation co-ordination, NEN-EN-IEC 60071-1 (Definitions, principles and rules), IEC 60071-2 (Application guide) and NPR-IEC/TR 60071-4 (Computational guide to insulation co-ordination and modelling of electrical networks), are:
 - Load rejection see 2.3.2.2 in IEC 60071-2;
 - Transformer energization and re-energisation after fault;
 - Parallel/series overhead line/ underground cable resonance;
 - Combination of transformer energization and overhead line/ underground resonance;
 - Uneven breaker poles;
 - Backfeeding;
 - Line fault application see 2.3.3.2 in IEC 60071-2;
 - Fault clearing see 2.3.3.2 in IEC 60071-2;
 - Line energization see 2.3.3.1 in IEC 60071-2;
 - Line re-energization;
 - Line dropping;
 - AIS busbar switching ;
 - Switching of inductive and capacitive current see 2.3.3.4 in IEC 60071-2,
 - Back flashover;
 - Direct lightning stroke see 2.3.3.5 in IEC 60071-2;
 - Switching inside GIS substation;
 - SF6 circuit-breaker inductive and capacitive current switching;
 - Flashover in GIS substation.

Annex: Requirements for (O)PPM EMT Simulation models

Abbreviations

EMT	Electromagnetic transient
FRT	Fault Ride Through
GCP	Grid Connection Point
GU	Generating Unit
PCC	Pont of Common Coupling
PGM	Power Generating Module
PGU	Power Generating Unit
(O)PPM	(Offshore) Power Park Module
TSO	Transmission System Operator
WTG	Wind Turbine Generator

1 Introduction

According to [1] and [2] simulation models need to be delivered to the TSO as part of the compliance process. A summary of the model requirements and deliverables of the Dutch TSO, TenneT, can be found in [3]. This document includes a more specific description of the types of models, model requirements and documentation needed.

2 Types of simulation models

Before granting the ION, the simulation (software) models shall be delivered by the connectee. Before granting the FON, the simulation models shall be updated with as-built data and validated with test results.

As mentioned in [3] the simulation models need to be suitable for performing load flow, short-circuit, harmonic (up to the 50th harmonic order) and dynamic simulations. As mentioned in the European RfG code, simulation models suitable for electromagnetic transients can be also requested by the TSO.

Table 1 contains the types of models and type of software to be used for each model.

Table 1. Types of models and type of software to be used for each model.

Type of model	Simulation software
RMS dynamic simulation models (for performing dynamic simulations, load flow and short-circuit) Both fully detailed and aggregated models need to be delivered.	PowerFactory and PSS/E
EMT simulation model	PSCAD

Note: In this document the requirements and deliverables for EMT simulation models are presented. For RMS model requirements and deliverables refer to Annex for RMS model requirements

The connectee needs to provide EMT simulation models and validation or benchmarking reports of the complete (O)PPM as well as of the Generating units (GU) to be connected to the (O)PPM.

3 Overview of deliverables

The connectee shall develop and provide to TenneT NL a tool-dependent EMT model of the (O)PPM in the software PSCAD.

- The model shall fulfil the model requirements as specified in Section 4
- The connectee shall validate the model as specified in Section 5 and 6
- The connectee shall document the model as specified in Section 7

4 EMT Model requirements

1. The connectee shall deliver the EMT model(s) using software version(s), that shall include the versions of Fortran Compiler and Visual Studio, as defined by TenneT.
2. The model shall be able to run on 64 and 32 bit systems.
3. If it is not possible to run the model with a variable time step in the range of μs , the model shall be able to run with time steps of 1 μs , 5 μs and 10 μs .
4. The model shall be valid in a frequency range between 0 Hz and 2500 Hz.
5. The model should be suitable for analysing the power electronic device dynamic behaviour focusing on the interaction of the control and protection system within the network in transient domain.
6. The model shall be valid for all operation points and operation modes in the positive-sequence, negative-sequence and zero-sequence systems.
7. The model should be able to reproduce the detailed response of the power-generating module and its control blocks during balanced and unbalanced AC network faults in the valid frequency range.
8. The model should be capable of numerical calculation of the frequency dependent impedance of the PGM at the connection point (impedance amplitude and impedance phase angle) in the frequency range that the model is valid.
9. The model shall automatically initialise for all operation points and operation modes and shall reach steady state operating point not later than 5 seconds of simulation time.
 - 1) The model shall be capable to specify a time point from which on the PGU and (O)PPM synchronise with the network and may supply power.
10. The model shall support the snapshot and multiple run function.
11. The model shall include predefined faults which are necessary to check FRT and fast fault-current injection behaviour of the (O)PPM. The fault characteristics shall be adjustable by the user.
12. Different parameters such as set-points, ramps, or relevant controller settings shall be adjustable by the user.
13. Tap changer control shall be included in the model, if applicable.
14. The model shall include a representation of wind turbine aerodynamic and mechanic system.
 - 1) On the aerodynamic side, the model shall consider the reactions of the wind turbine with effect on energy conversion (e.g. speed change).
 - 2) The model shall represent the mechanical dynamics (such as inertial response from the wind turbine), which have an influence on the electrical behaviour.
15. There shall be a reference in the model to the software version(s) embedded in the

- PPM and power generating unit hardware that the model corresponds to.
16. The model shall consider all design limits.
 17. The model shall include the original source code of the controller of all required functions which are active in the specified frequency range for this model.
 18. The simulation models should include the PGM up to the Connection Point, including individual Generating Units, as transmission and distribution lines and cables, transformers, loads, generators, shunt compensation etc., up to the Connection Point.
 - 1) The model shall include at least one string with largest length in full details per GCP or $PCC_{ACoff,X}$ including all WTGs and WTG-transformers, inter-array cables. The rest of the wind farm inter array cable grid may be reduced. The aggregation method must be clearly documented.
 - 2) The model shall contain frequency dependent model for the cable.
 - 3) Voltage controllers, power controllers and Power Park controllers must be incorporated in the model.
 - 4) Auxiliaries and any other compensation equipment (filters, shunts etc.) need to be included in the model.
 19. The model shall contain protection functions incl. nonlinearities of instrument transformers and time delays caused by e.g. signal processing:
 - 1) All protection functions that may potentially lead to tripping or (temporary) blocking of PPM and PGU after an event in the connected AC networks (including submodule level protective actions)
 - 2) With the model for protection functions, the connectee shall ensure, that TenneT can reliably assess whether PPM and PGU trips or (temporarily) blocks in case of any event in the connected AC system.
 - 3) The protection functions including their triggering values shall be described in the model documentation.
 - 4) All protection functions shall be observable in the model, providing the information why and when the PPM and PGU has tripped or (temporarily) blocked.
 - 5) The connectee shall test all protection functions in an adequate manner and describe them as part of the documentation.
 20. If the model contains encoded parts, the following requirements shall be fulfilled:
 - 1) If it is necessary to encode parts of the model due to intellectual property reasons, only the control code may be encoded.
 - 2) A signal-flow-diagram of the encoded parts shall be provided.
 - 3) Park-level control block shall not be encrypted.
 - 4) Alternatively, if for practical reasons, the park-level controls are encrypted, control block diagrams fully describing the controllers including parameter set shall be provided.
 - 5) The park-level controls shall be provided with original controller code or in DLL format.
 - 6) Supplementary stability functions, i.e. AC voltage control, active and reactive power control, LFSM-O/U, FSM and EPC function (if applicable)

- shall be fully accessible.
21. If parts or the control is encoded, the following signals, settings and parameters shall be accessible and adjustable respectively for TenneT:
 - Dynamic active current limitation,
 - Dynamic reactive current limitation,
 - Protection activate or deactivate and information which protection system (inclusive cell level protective actions) is triggered,
 - Signals which are used to trigger protection systems,
 - All reference signals which are relevant for the control systems,
 - Measured and filtered voltage and current signal before it is used in the control,
 - Measured frequency used for dq transformation,
 - Output signals of required functions and control modes according to the grid code,
 - Set-points of all required functions and control modes according to the grid code [Active power control, Power factor control ($\cos \varphi$ control), Q control (MVar control), Voltage control including parameters for droop used, Frequency control (droop and deadband), System protection measures],
 - Parameters of all required functions and control modes according to the grid code,
 - Activation / deactivation of the Chopper (if applicable),
 - Chopper state (energy/thermal performance), if applicable,
 - All relevant variables required for compliance with the grid code.
 22. In the model shall at least the following signals be accessible for the user:
 - AC voltage (magnitude and phase angle) and frequency at PCC of all (O)PPMs and at the grid side of the transformer of all PGUs.
 - Active and reactive power of the converters at PCC of all (O)PPMs and at the grid side of the transformer of all PGUs.
 - Active positive and negative sequence currents of the converters at PCC of all (O)PPMs and at the grid side of the transformer of all PGUs.
 - Reactive positive and negative sequence currents of the converters at PCC of all (O)PPMs and at the grid side of the transformer of all PGUs.
 - Positive and negative sequence voltages of the converters at PCC of all (O)PPMs and at the grid side of the transformer of all PGUs.
 - Phase angle for the positive sequence voltages of the converters at PCC of all (O)PPMs and at the grid side of the transformer of all PGUs.
 23. The model shall include a graphical user interface, e.g. with buttons, sliders and switches for adjusting different switching configurations, set-points and controls modes for the model of all PPMs and PGUs:
 - Selection of all control modes according to grid code,
 - Set-points of different control modes,
 - Wind speed and or active power set point,
 - factor for the scaling of the PGU,

- State of all circuit breakers,

5 EMT GU models and validation

Model validation of wind energy generation systems is the draft for IEC 61400-27-2 [6].

Model validation of other energy driven systems is expected to follow the same procedure.

The connectee should deliver validation reports of the generating unit model where the simulation results are compared with measurements.

1. The GU should be validated for:
 - Fault ride through capability
 - Active Power control
 - Reactive power reference control
 - Reactive power – voltage reference control
2. The connectee shall use at least the following benchmark scenarios to validate the EMT model:
 - AC faults (symmetrical and unsymmetrical),
 - Step response tests of relevant control functions,
 - Functional tests of relevant control functions (e.g. AC voltage control, active and reactive power control, LFSM-O/U, FSM, EPC activation (if applicable),
3. The test cases shall be further developed jointly by the connectee and TTG and shall be approved by TTG.
4. The connectee shall verify the GU RMS models with the following limits:
 - 1) The connectee shall apply a maximum of 5 % (of the nominal values) margin of deviation in the electrical quantities (voltage, current etc.) as the steady-state validation criteria.
 - 2) The connectee shall provide a technical explanation for the cases that exceed a 10 % deviation margin as transient validation criterion.

6 EMT (O)PPM Model Validation

The connectee shall deliver validation and benchmarking reports together with the simulation models.

For FON (the simulation models shall be updated with as-built data and validated with test results):

1. Validation of the EMT (O)PPM model. For this the EMT model will be compared with measurements performed as part of the FON tests. The required Grid Code Compliance tests for validation purposes are:
 - Frequency Response Tests (LFSM-O/U and FSM)
 - Reactive Power Control Tests (Voltage control mode, Reactive power control model, power factor control mode)

- Power Oscillation Damping control or Power System Stabiliser
2. The actual set points and measurements taken during the Grid Code Compliance tests should be considered for validation purposes.
 3. If any control parameters have been re-tuned during commissioning tests, these should be highlighted in the report and the updated parameters and set values should be submitted to TenneT.
 4. The simulation outputs of the submitted model should be compared against recorded results of the tests at the physical site. The comparison can be done by plotting the outputs on graphs. Evaluation on the obtained results is required.
 5. TenneT is primarily interested in the verification of the dynamic aspects of the Grid Code tests. For the tests with extensive duration, it is possible to split the simulations and focus only on the time periods where the dynamic response is provided.
 6. For the validation of the EMT simulation model with FON measurements and EMT model:
 - 1) The connectee shall apply a maximum of 5% (of the nominal values) margin of deviation in the electrical quantities (voltage, current etc.) as the steady-state validation criteria.
 - 2) The connectee shall provide a technical explanation for the cases that exceed a 10% deviation margin as transient validation criterion.

7 EMT Model documentation

The model documentation shall at least include the following aspects:

- Model user manual,
- Model validation documentation,
- Literature and bibliography (references),
- Stage of development of the models and its control functions, control modes and control parameters (if applicable),
- Types of studies/analyses for which the model is valid.

EMT Model user manual

1. The model user manual for GU and (O)PPM shall include a suitable description of the model:
 - 1) The documentation shall include a single line diagram indicating the in- and output parameters and variables.
 - 2) The names and units of in- and output parameters and variables shall be described in detail.
 - 3) The HMI of the model, meaning the parameters adjustable by the user shall be highlighted in the model and clearly described in terms of unit, parameter range, default values etc.
 - 4) Other main parameters of the model, which are not adjustable but relevant for the user, like nominal power, point of connection, etc. shall be given in

the model.

- 5) The control scheme shall be described by block diagrams.
- 6) Any limits in terms of operational ranges, time steps etc. shall be described.
- 7) A guideline how to integrate the model in other simulation projects in the specific software shall be part of the manual.
- 8) A description how to operate the model shall be added to the manual.
- 9) Indication of any limitations and assumptions of the models, including the full range of grid strength the model is designed for and the acceptable step sizes.
- 10) Description of the module/function settings needed for different operational scenarios, for example, different operational modes of converters, different system strength of the network etc.
- 11) List and description of operating modes of the converters and their applicable network scenarios.
- 12) List and description of all the simplifications used in the model.
- 13) List and description of any modules and functions that are not included in the model.
- 14) Guidance on the interpretation of error messages and troubleshooting

EMT Model Validation reports

2. All model validation documentation shall at least include the following aspects:
 - Summary and interpretation of results,
 - Justification for any deviations larger than defined values,
 - Assumptions and data used,
 - Literature and bibliography(references),
 - Applied software, incl. the version number.

FON deliveries

3. Validation report of the EMT (O)PPM model with measurements. In this report the EMT detailed (O)PPM model will be compared with measurements performed as part of the FON tests. The required Grid Code Compliance tests for validation purposes are:
 - Frequency Response Tests (LFSM-O/U and FSM)
 - Reactive Power Control Tests
 - Power Oscillation Damping control or Power System Stabiliser

References

- [1] Grid Code; Netcode elektriciteit. Link: <https://wetten.overheid.nl/BWBR0037940> (check for the latest version)
- [2] EU regulation 2016/631: NC RfG
- [3] “Power-Generating Modules compliance verification. Power-Generating Modules type B. C and D according to NC RfG and Netcode elektriciteit”; Netbeheer Nederland; Link: <https://www.netbeheernederland.nl/dossiers/regulering-20/documenten>
- [4] IEC 61400-27-1:2020, “Wind energy generation systems - Part 27-1: Electrical simulation models - Generic models”.
- [5] IEC 61400-27-2:2020, “Wind energy generation systems - Part 27-2: Electrical simulation models - Model validation”.
- [6] Technische Richtlijnen für Erzeugungseinheiten und -anlagen – Teil 4: Anforderungen an Modellierung und Validierung von Simulationsmodellen der elektrischen Eigenschaften von Erzeugungseinheiten und -anlagen (TR 4), Stand 05.04.2022, FGW e.V.

Annex: Requirements for RMS Simulation models

Abbreviations

EMT	Electromagnetic transient
FRT	Fault Ride Through
GCP	Grid Connection Point
GU	Generating Unit
PGM	Power Generating Module
PF	PowerFactory
(O)PPM	(Offshore) Power Park Module
TSO	Transmission System Operator
WTG	Wind Turbine Generator

1 Introduction

According to [1] and [2] simulation models need to be delivered to the TSO as part of the compliance process. A summary of the model requirements and deliverables of the Dutch TSO, TenneT, can be found in [3]. This document includes a more specific description of the types of models, model requirements and documentation needed.

2 Types of simulation models

Before granting the ION, the simulation (software) models shall be delivered by the connectee. Before granting the FON, the simulation models shall be updated with as-built data and validated with test results.

As mentioned in [3] the simulation models need to be suitable for performing load flow, short-circuit, harmonic (up to the 50th harmonic order) and dynamic simulations. As mentioned in the European RfG guideline, simulation models suitable for electromagnetic transients can be also requested by the TSO.

Table 1 contains the types of models and type of software to be used for each model.

Table 2. Types of models and type of software to be used for each model.

Type of model	Simulation software
RMS dynamic simulation models (for performing dynamic simulations, load flow and short-circuit) Both fully detailed and aggregated models need to be delivered.	PowerFactory (PF) and PSS/E
EMT simulation model	PSCAD

Note: In this document the requirements and deliverables for RMS simulation models are presented. For EMT model requirements and deliverables refer to Annex for EMT model requirements

The connectee needs to provide RMS simulation models and validation or benchmarking reports of the complete (O)PPM as well as of the Generating units (GU) to be connected to the (O)PPM.

3 Overview of deliverables

This section provides a brief summary of the RMS dynamic simulation model deliverables.

The connectee shall develop and provide to TenneT NL a tool-dependent RMS model of the (O)PPM in the softwares PowerFactory and PSS/E.

- The models shall fulfil the model requirements as specified in Section 4.
- The connectee shall validate the models as specified in Section 5 and 6.
- The connectee shall document the models as specified in Section 7.
-

4 RMS Model Requirements

1. The fully detailed simulation models should include the PGM up to the Connection Point, including individual Generating Units, as transmission and distribution lines and cables, transformers, loads, shunt compensation etc., up to the Connection Point.
2. For the aggregated models, each Power-Generating Facility shall be delivered as an entity compiled into a minimum number of single equivalent generators. The model shall cover – alongside the equivalent generators – the transformers needed to connect the generators and the Power-Generating Facility to the power system. This aggregation level should be adequate for the optimal use of the dynamic simulation models for Generating Unit controller and PGM controller.
3. The aggregated model shall be described by means of generic terms and parameters given by IEC 61400-27 series (or WECC for PSS/E).
4. Voltage controllers, power controllers and power park controllers must be incorporated in the model.
5. The model shall include a proper representation of the converter modules and its control systems (including the synchronization module) that influence the dynamic behaviour of the power generating module in the specified time frame up to and including 3 Hz.
6. If the model contains encoded parts, the following requirements shall be fulfilled:
 - 1) Park-level control blocks shall not be encrypted in the RMS model.
 - 2) Alternatively, if for practical reasons, the grid-level and station level controls are encrypted, control block diagrams fully describing the controllers including parameter set shall be provided.
 - 3) the following signals, settings and parameters shall be accessible and adjustable respectively for TenneT:
 - Dynamic active current limitation
 - Dynamic reactive current limitation
 - All required functions and control modes according to the grid code,
 - Set-points of all required functions and control modes according to the grid code,
 - Parameters of all required functions and control modes according to the grid code,
Informative: The different parameters should be changeable to simulate the different behaviour of new customer installation.
 - Activation / deactivation of the chopper (if applicable),

7. The park-level controls shall be provided with original controller code or in DLL format according to EN 61400-27-1:2017-05, Appendix F.
8. Supplementary stability functions, i.e. AC voltage control, active and reactive power control, LFSM-O/U, FSM and EPC activation (if applicable) shall be fully accessible in the RMS model.
9. Primary equipment shall not be encoded.
10. Protection function models shall be also included in the model.
 - 1) The connectee shall describe which protection functions of the detailed EMT model can be realistically represented in the RMS models and represent them in the RMS model.
11. Auxiliaries and any other compensation equipment (filters, shunts etc.) need to be included in the model.
12. All models shall be delivered in latest versions of both PSS/E and PowerFactory format.
13. The model shall be able to run on 64 and 32 bit systems.
14. The model shall be valid for all defined operation points and operation modes (all control modes of the power-generating facility).
15. Different parameters such as set-points, ramps shall be adjustable by the user. It shall be clear how to change the operating set-points used for compliance verification.
16. The model shall automatically initialise for all operation points within all operation modes and remain stable.
17. The model shall be suitable for performing power system stability, including voltage stability, frequency stability and rotor angle stability simulations.
18. The simplification of the synchronisation mechanism of the converter (PLL) shall be justified, if applicable.
19. The model shall consider all design limits.
20. The model shall include all required functions according to the grid code which are active in the specified time range.
21. The model shall include predefined faults which are necessary to perform the system conformity study. The faults shall be adjustable.

5 RMS GU models and validation

Model validation of wind energy generation systems is the draft for IEC 61400-27-2 [6]. Model validation of other energy driven systems is expected to follow the same procedure. The connectee should deliver validation reports of the generating unit model where the simulation results are compared with measurements. For type C and D PGMs, validation reports of both the PowerFactory and the PSS/E generating unit models are required. For type B PGMs, validation reports of either PowerFactory or the PSS/E generating unit models are required.

1. As described in IEC 61400-27-2 the GU should be validated for:
 - Fault ride through capability
 - Active Power control

- Frequency control
 - Reactive power reference control
 - Reactive power – voltage reference control
2. The connectee shall use at least the following benchmark scenarios to validate the RMS model:
 - AC faults (symmetrical and unsymmetrical),
 - Step response tests of relevant control functions,
 - Functional tests of relevant control functions (e.g. AC voltage control, active and reactive power control, LFSM-O/U, FSM, EPC activation (if applicable),
 3. The connectee shall verify the GU RMS models with the following limits:
 - 1) The connectee shall apply a maximum of 5 % (of the nominal values) margin of deviation in the electrical quantities (voltage, current etc.) as the steady-state validation criteria. In case the margin is exceeded a technical explanation should be provided and assessed by the TSO.
 - 2) The connectee shall apply a maximum of 10 % deviation margin in the electrical quantities (voltage, current etc.) as transient validation criterion. In case the margin is exceeded a technical explanation should be provided and assessed by the TSO.

6 RMS (O)PPM Model Validation

The connectee shall deliver validation and benchmarking reports together with the simulation models.

For ION:

1. Benchmarking of the PSS/E fully detailed model. For this the (O)PPM PSS/E model will be compared with the fully detailed PF (O)PPM model for several symmetrical and asymmetrical fault cases as well as for active and reactive power control (Setpoint, LFSM-O/U and FSM, EPC, etc. if available in WTG control).
2. Benchmarking of the aggregated PowerFactory (O)PPM model (modelled using IEC generic parameters). For this the (O)PPM aggregated PF IEC model will be compared with the fully detailed PF (O)PPM model for several symmetrical and asymmetrical fault cases as well as for active and reactive power control (Setpoint, LFSM-O/U and FSM, EPC, etc. if available in WTG control).
3. Benchmarking of the aggregated PSS/E (O)PPM model (modelled using WECC generic parameters). For this the (O)PPM aggregated PSS/E WECC model will be compared with the fully detailed PF (O)PPM model for several symmetrical and asymmetrical fault cases as well as for active and reactive power control (Setpoint, LFSM-O/U and FSM, EPC, etc. if available in WTG control).
4. For the benchmarking where other RMS simulation models are compared with the fully detailed PowerFactory model:
 - 1) The connectee shall apply a maximum of 5% (of the nominal values) margin of deviation in the electrical quantities (voltage, current etc.) as the steady-state validation criteria. In case the margin is exceeded a technical

explanation should be provided and assessed by the TSO.

- 2) The connectee shall apply a maximum of 10% deviation margin in the electrical quantities (voltage, current etc.) as transient validation criterion. In case the margin is exceeded a technical explanation should be provided and assessed by the TSO.

For FON (the simulation models shall be updated with as-built data and validated with test results):

5. Validation of the PowerFactory detailed (O)PPM model. For this the PowerFactory detailed (O)PPM model will be compared with measurements performed as part of the FON tests. The required Grid Code Compliance tests for validation purposes are:
 - Frequency Response Tests (LFSM-O/U and FSM)
 - Reactive Power Control Tests (Voltage control mode, Reactive power control model, power factor control mode)
 - Power Oscillation Damping control or Power System Stabiliser
6. The actual set points and measurements taken during the Grid Code Compliance tests should be considered for validation purposes.
7. If any control parameters have been re-tuned during commissioning tests, these should be highlighted in the report and the updated parameters and set values should be submitted to TenneT.
8. The simulation outputs of the submitted model should be compared against recorded results of the tests at the physical site. The comparison can be done by plotting the outputs on graphs. Evaluation on the obtained results is required.
9. TenneT is primarily interested in the verification of the dynamic aspects of the Grid Code tests. For the tests with extensive duration, it is possible to split the simulations and focus only on the time periods where the dynamic response is provided.
10. For the validation of the (O)PPM model behaviour for AC faults (symmetrical and asymmetrical) the fully detailed PowerFactory RMS model should be compared with the (O)PPM EMT simulation model for selected fault cases.
11. For the validation of the fully detailed RMS simulation model with FON measurements and EMT model:
 - 1) The connectee shall apply a maximum of 5% (of the nominal values) margin of deviation in the electrical quantities (voltage, current etc.) as the steady-state validation criteria. In case the margin is exceeded a technical explanation should be provided and assessed by the TSO.
 - 2) The connectee shall apply a maximum of 10% deviation in the electrical quantities (voltage, current etc.) margin as transient validation criterion. In case the margin is exceeded a technical explanation should be provided and assessed by the TSO.

7 RMS Model documentation

The model documentation shall at least include the following aspects:

- Model user manual,
- Model validation documentation,
- Literature and bibliography (references),
- Stage of development of the models and its control functions, control modes and control parameters (if applicable),
- Types of studies/analyses for which the model is valid.

RMS Model user manual

1. The model user manual for GU and (O)PPM shall include a suitable description of the model:
 - 1) The documentation shall include a single line diagram indicating the in- and output parameters and variables.
 - 2) The names and units of in- and output parameters and variables shall be described in detail.
 - 3) The HMI of the model, meaning the parameters adjustable by the user shall be highlighted in the model and clearly described in terms of unit, parameter range, default values etc.
 - 4) Other main parameters of the model, which are not adjustable but relevant for the user, like nominal power, point of connection, etc. shall be given in the model.
 - 5) The control scheme shall be described by block diagrams.
 - 6) Any limits in terms of operational ranges, time steps etc. shall be described.
 - 7) A guideline how to integrate the model in other simulation projects in the specific software shall be part of the manual.
 - 8) A description how to operate the model shall be added to the manual.

RMS Model Validation reports

2. All model validation documentation shall at least include the following aspects:
 - Summary and interpretation of results,
 - Justification for any deviations larger than defined values,
 - Assumptions and data used,
 - Literature and bibliography(references),
 - Applied software, incl. the version number.

ION deliveries

3. Benchmarking report of the PSS/E fully detailed model as mentioned in 6.1.
4. Benchmarking report of the aggregated PowerFactory (O)PPM model as mentioned in 6.2.
5. Benchmarking report of the aggregated PSS/E (O)PPM model as mentioned in 6.3.

FON deliveries

6. Benchmarking report of the PowerFactory detailed (O)PPM model with EMT model. The fully detailed PowerFactory (O)PPM model should be compared with the (O)PPM EMT simulation model for selected fault cases.
7. Validation report of the PowerFactory detailed (O)PPM model with measurements as mentioned in 6.5.

References

- [1] Grid Code; Netcode elektriciteit. Link: <https://wetten.overheid.nl/BWBR0037940> (check for the latest version)
- [2] EU regulation 2016/631: NC RfG
- [3] “Power-Generating Modules compliance verification. Power-Generating Modules type B, C and D according to NC RfG and Netcode elektriciteit”; Netbeheer Nederland; Link: <https://www.netbeheernederland.nl/dossiers/regulering-20/documenten>
- [4] IEC 61400-27-1:2020, “Wind energy generation systems - Part 27-1: Electrical simulation models - Generic models”.
- [5] “WECC Approved Dynamic Model Library”, WECC, December 2021. Available on: [https://www.wecc.org/Reliability/Approved Dynamic Models December 2021.pdf](https://www.wecc.org/Reliability/Approved%20Dynamic%20Models%20December%202021.pdf)
- [6] IEC 61400-27-2:2020, “Wind energy generation systems - Part 27-2: Electrical simulation models - Model validation”.